



PACIFIC[®]
F L O O R C A R E

S-20 / S-24XM

11 GALLON AUTOSCRUBBER



Thank you for purchasing a Pacific Floorcare product. Carefully inspect all components for freight damage. If such damage is discovered, file a “CONCEALED DAMAGE REPORT” immediately with the delivering carrier.

Read this manual carefully and keep it near the machine, protected from liquids and other damaging substances. Failure to follow the instructions may result in injury or damage to equipment and property.

The contents of this manual are based on the latest product information available at the time of publication. Pacific Floorcare reserves the right to make changes or improvements without being obliged to apply changes to the machines previously sold.

New manuals can be downloaded from: www.pacificfloorcare.com/manuals

11 GALLON AUTOSCRUBBER SPECIFICATIONS

Features	Specifications		
Model	S-20 Disk Pad Assist	S-20 Disk Transaxle Drive	S-20HD Disk Transaxle Drive
Solution Delivery System			
Solution Capacity:	11 gal / 42 l	11 gal / 42 l	11 gal / 42 l
Solution Control:	0-.5 gpm / 1-1.9 lpm Variable Knob Adjustment	0-.5 gpm / 1-1.9 lpm Variable Knob Adjustment	0-.5 gpm / 1-1.9 lpm Variable Knob Adjustment
Scrubbing System			
Cleaning Path:	20 in / 510 mm	20 in / 510 mm	20 in / 510 mm
Pad/Brush Size:	(1) 20 in / 510 mm	(1) 20 in / 510 mm	(1) 20 in / 510 mm
Productivity (per hour) - Theoretical Max:	23,800 ft ² / 2.211 m ²	23,800 ft ² / 2.211 m ²	23,800 ft ² / 2.211 m ²
Productivity (per hour) - Average Coverage Rate:*	10,630 ft ² / 988 m ²	14,175 ft ² / 1,317 m ²	14,175 ft ² / 1,317 m ²
Brush Drive System			
Brush Motor Horsepower:	.75 hp / 560 W	.75 hp / 560 W	1 hp / 750 W
Brush RPM:	230 RPM	230 RPM	220 RPM
Brush / Pad Pressure:	60 & 90 lb / 27 & 41 kg	60 & 90 lb / 27 & 41 kg	60 & 90 lb / 27 & 41 kg
Brush / Pad Attachment / Removal:	Auto on/off	Auto on/off	Auto on/off
Recovery System			
Recovery Tank Accessibility:	Full Cleanout Access	Full Cleanout Access	Full Cleanout Access
Recovery Tank Capacity:	13 gal / 49 l (2 gal / 7.6 l demisting chamber)	13 gal / 49 l (2 gal / 7.6 l demisting chamber)	13 gal / 49 l (2 gal / 7.6 l demisting chamber)
Vacuum Motor:	.51 hp / 380 W , 2-stage	.51 hp / 380 W , 2-stage	.51 hp / 380 W , 2-stage
Vacuum Motor cfm / cmm:	68 cfm / 1.9 cmm	68 cfm / 1.9 cmm	68 cfm / 1.9 cmm
Vacuum Motor Water-Lift:	46 in / 117 cm	46 in / 117 cm	46 in / 117 cm
Squeegee Width:	30 in / 76 cmm	30 in / 76 cmm	30 in / 76 cmm
Drive System			
Drive Type:	Pad Assist	Transaxle Drive	Transaxle Drive
Motor Horsepower:	NA	.25 hp / 187 W	.25 hp / 187 W
Battery System			
System Voltage:	24V	24V	24V
Battery Amp Hour Rating:	130 AH (wet) / 105 AH (MF)	155 AH (wet) / 140 AH (MF)	155 AH (wet) / 140 AH (MF)
Battery Run Time:	Up to 3 hours	Up to 3.5 hours	Up to 3.5 hours
Charger Description:	On-board (standard) Off-board (optional)	On-board (standard) Off-board (optional)	On-board (standard) Off-board (optional)
Machine Specifications			
Product Length:	50 in / 127 cm	50 in / 127 cm	50 in / 127 cm
Product Width (w/o squeegee):	21 in / 53 cm	21 in / 53 cm	21 in / 53 cm
Product Height:	43 in / 109 cm	43 in / 109 cm	43 in / 109 cm
Product Weight:	380 lb / 172kg	400 lb / 181kg	400 lb / 181kg
Sound Level (operator's ear):	63 dBA	63 dBA	63 dBA
Construction:	Rotationally molded polyethylene tanks, powder coated steel frame	Rotationally molded polyethylene tanks, powder coated steel frame	Rotationally molded polyethylene tanks, powder coated steel frame
*Productivity calculations utilize key factors from ISSA 540 cleaning times handbook			
Note: Specifications subject to change without notice			

11 GALLON AUTOSCRUBBER SPECIFICATIONS

Features	Specifications	
Model:	S-20 Orbital	S-24XM Disk
Solution Delivery System		
Solution Capacity:	11 gal / 42 l	11 gal / 42 l
Solution Control:	0-.5 gpm / 1-1.9 lpm Variable Knob Adjustment	0-.5 gpm / 1-1.9 lpm Variable Knob Adjustment
Scrubbing System		
Cleaning Path:	20 in / 510 mm	20 in / 510 mm
Pad/Brush Size:	(1) 20 in / 510 mm	(1) 20 in / 510 mm
Productivity (per hour) - Theoretical Max:	23,800 ft ² / 2.211 m ²	23,800 ft ² / 2.211 m ²
Productivity (per hour) - Average Coverage Rate:*	14,175 ft ² / 1,317 m ² (scrubbing) 9,000 ft ² / 836 m ² (finish removal at 100 ft/min / 30 m/min)	17,325 ft ² / 1,610 m ²
Brush Drive System		
Brush Motor Horsepower:	1 hp / 750 W	1 hp / 750 W
Brush RPM:	2,200 RPM	360 RPM
Brush / Pad Pressure:	75 & 100 lb / 34 & 45 kg	60 & 90 lb / 27 & 41 kg
Brush / Pad Attachment / Removal:	Manual	Auto on/off
Recovery System		
Recovery Tank Accessibility:	Full Cleanout Access	Full Cleanout Access
Recovery Tank Capacity:	13 gal / 49 l (2 gal / 7.6 l demisting chamber)	13 gal / 49 l (2 gal / 7.6 l demisting chamber)
Vacuum Motor:	.51 hp / 380 W , 2-stage	.51 hp / 380 W , 2-stage
Vacuum Motor cfm / cmm:	68 cfm / 1.9 cmm	68 cfm / 1.9 cmm
Vacuum Motor Water-Lift:	46 in / 117 cm	46 in / 117 cm
Squeegee Width:	30 in / 76 cmm	30 in / 76 cmm
Drive System		
Drive Type:	Traction	Transaxle
Motor Horsepower:	.25 hp / 187 W	.25 hp / 187 W
Battery System		
System Voltage:	24V	24V
Battery Amp Hour Rating:	155 AH (wet) / 140 AH (MF)	130 AH (wet) / 105 AH (MF)
Battery Run Time:	Up to 4 hours	Up to 3.5 hours
Charger Description:	On-board (standard) Off-board (optional)	On-board (standard) Off-board (optional)
Machine Specifications		
Product Length:	45 in / 114 cm	48 in / 122 cm
Product Width (w/o squeegee):	21 in / 53 cm	26 in / 66 cm
Product Height:	43 in / 109 cm	43 in / 109 cm
Product Weight:	400 lb / 181kg	410 lb / 186kg
Sound Level (operator's ear):	60 dBA	63 dBA
Construction:	Rotationally molded polyethylene tanks, powder coated steel frame	Rotationally molded polyethylene tanks, powder coated steel frame
*Productivity calculations utilize key factors from ISSA 540 cleaning times handbook		
Note: Specifications subject to change without notice		

TABLE OF CONTENTS

SAFETY INFORMATION	1
UNPACKING THE MACHINE	3
TRANSPORTING THE MACHINE	3
BATTERIES	4
SERVICING LEAD ACID BATTERIES (NON-HYDROLINK® MODELS)	5
SERVICING LEAD ACID BATTERIES WITH HYDROLINK® WATERING SYSTEM.....	6
BATTERYSHIELD® AUTOMATED WET BATTERY PROTECTION SYSTEM.....	6
CLEANING THE BATTERYSHIELD® SENSOR LIGHT PIPE	7
CHARGING	8
ON-BOARD CHARGING	8
OFF-BOARD CHARGING	9
OPERATION	10
MACHINE OVERVIEW	10
DRIVE SYSTEM (TRACTION MODELS)	12
OPTIONAL SCRUBSMART TELEMETRY SYSTEM	12
SOLUTION DISTRIBUTION.....	12
SCRUB HEAD	13
ORBITAL SCRUB HEAD & CHEMICAL-FREE FINISH REMOVAL.....	14
DISK SCRUB HEAD	15
RECOVERY SYSTEM.....	16
RECOMMENDED MAINTENANCE	19
RECOMMENDED SERVICE PARTS	21
TROUBLESHOOTING GUIDE	25
PARTS DIAGRAMS	27
FRAME ASSEMBLY	27
HEAD LIFT	29
ELECTRONICS.....	33
BATTERY	34
CONTROLS.....	35
OPTIONAL SCRUBSMART TELEMETRY SYSTEM	40
RECOVERY TANK ASSEMBLY	41
RECOVERY TANK ASSEMBLY	42
SQUEEGEE LINKAGE	45
SQUEEGEE ASSEMBLY	46
ON-BOARD CHARGER (OPTIONAL).....	47
PAD ASSIST DISK SCRUB HEAD	49
TRACTION DISK SCRUB HEAD.....	51
S-20HD DISK SCRUB HEAD.....	53
ORBITAL SCRUB HEAD.....	55
S-24XM SCRUB HEAD	59
ELECTRICAL DIAGRAMS	61
S-20 TRACTION (DISK) & S-24XM.....	61
S-20 ORBITAL	63
S-20 PAD/BRUSH ASSIST	65
OPTIONAL SCRUBSMART TELEMETRY SYSTEM	66

PAGE INTENTIONALLY BLANK

SAFETY INFORMATION

This machine is intended for commercial use. Only use recommended pads or brushes and commercially approved floor cleaning chemicals intended for machine application.

WARNING: A potentially hazardous situation that, if not avoided, could result in death or serious injury.

CAUTION: A potentially hazardous situation that, if not avoided, could result in moderate injury or serious property damage.

NOTE: Information that will prevent premature equipment failure or minor property damage.

WARNING: This product can expose you to chemicals including lead and lead compounds which are known to the State of California to cause cancer and birth defects or other reproductive harm. For more information go to www.P65Warnings.ca.gov.

WARNING: This machine is not equipped with explosion proof motors. Never use near flammable or reactive materials, liquids, vapors or combustible dusts. Electric motors spark internally during operation and could cause a flash fire or explosion.

WARNING: Never circumvent safety devices such as circuit breakers or fuses.

WARNING: Batteries emit hydrogen and oxygen gas.

- Keep sparks and open flame away.
- Do not smoke near the machine.
- Charge batteries in a well-ventilated area with the battery compartment open.

WARNING: Do not plug in the charger cable if wall cord or battery harness is damaged.

WARNING: Disconnect battery cables before servicing.

WARNING: Do not wear jewelry when working near moving or electrical components.

WARNING: Do not use the machine as a means for transport.

WARNING: Never allow children to play on or around machine.

WARNING: Do not bump into shelves or scaffoldings, especially where there is a risk of falling objects.

WARNING: Support the machine on safety stands before working underneath.

WARNING: Do not operate the machine:

- Unless trained and authorized.
- Unless operator manual has been fully read and understood.
- While using cell phones or other electronic devices.
- Under the influence of drugs or alcohol.
- With any part of the machine not functioning properly, including electrical or mechanical safety devices.
- In areas where flammable vapors, liquids, or combustible dusts are present.
- In low light areas where the operators vision is impaired.
- In areas with possible falling objects.

WARNING: Before operating the machine:

- Check the machine and batteries for fluid leaks.
- Check the steering and brake systems for proper operation.

WARNING: While operating the machine:

- Operate the machine only as described in this manual.
- Allow the machine to fully stop before getting off.
- Keep all body parts inside the machine while moving.
- Do not carry passengers on the machine.
- Follow all safety instructions and guidelines specific to your facility or environment.

SAFETY INFORMATION

CONTINUED

- CAUTION:** Keep hands away from spinning brushes.
- CAUTION:** Do not modify the machine from its original design.
- CAUTION:** Wear non-slip shoes when operating machine.
- CAUTION:** Reduce speed when turning or operating on inclines and slippery surfaces.
- CAUTION:** Use Bromine only in your tank treatment system! Do not use chlorine. Chlorine can interact with ammonia-based detergents and cause harmful fumes.
- CAUTION:** Follow mixing and handling instructions on chemical containers.
- CAUTION:** Remove the batteries, use a jack, and get assistance before lifting the machine.
- CAUTION:** Park and service the machine on a level surface and remove the key.
- CAUTION:** Always wear protective clothing, gloves and goggles when handling and charging batteries.
- CAUTION:** Avoid moving parts and do not wear loose jackets, shirts or sleeves when servicing.
- NOTE:** Do not hose down or use a power-spray on the machine. Electrical malfunction may occur.
- NOTE:** All repairs must be performed by a qualified service technician using approved replacement parts.
- NOTE:** To avoid damaging the floor, do not allow the brush/pad to operate while the machine is stationary.
- NOTE:** Use a ramp with no more than a 12% incline when loading or unloading the machine.
- NOTE:** Use tie down straps to secure the machine to the truck or trailer during transport.
- NOTE:** Discontinue use and report machine damage or faulty operation immediately.
- NOTE:** Store the machine indoors where the temperature is between 32° and 104°F (0° and 40°C).
- NOTE:** Do not lower the orbital head without a pad. Doing so damages the Mighty-Lok® face.
- NOTE:** Failure to clean the BatteryShield® light pipe will limit the system's ability to read the water level and will reduce battery life.
- NOTE:** Do not use an extension cord. This will void the warranty on the charger.
- NOTE:** Batteries designed for automotive or marine and RV use are not suited for use in floor scrubbers.
- NOTE:** Use of an unapproved water supply or modification of an approved water supply can lead to battery system failure.
- NOTE:** Ensure battery charging and storage locations comply with OSHA and any governing agencies' standards based on your particular location and application.
- NOTE:** Use of caustic, high ph, or degreasing chemicals can decrease the service life of components, including the orbital head bearings.
- NOTE:** When loading/unloading machine for transport:
- Fully drain the Solution and Recovery tanks before loading.
 - Transport the machine with the scrub head in the lowered.
 - Ensure the ramp and truck/trailer are properly rated for the weight of the machine.
 - Do not lower the Orbital Scrub Head without a pad installed.
 - Chock the wheels and tie down the machine.
- NOTE:** A valid user code must be entered into the telemetry system keypad (on all telemetry-equipped machines) before the machine can be operated.

UNPACKING THE MACHINE

1. Remove outer cardboard packaging.
2. Remove the shrink wrap securing the ramp and allow the ramp (not shown) to lower to the ground.
3. Using a #2 Philips driver, remove the screws from the front and rear wood wheel chocks.
4. Using a 3/8" socket and driver or wrench, remove the screws from the tie-down straps located at each corner of the machine.
5. Raise the scrub head to the transport position.
6. Carefully maneuver the machine down the ramp.
7. Install the rear squeegee assembly.



TRANSPORTING THE MACHINE

CAUTION: Remove the batteries and use mechanical assistance to lift machine manually.

NOTE: Fully drain the Solution and Recovery tanks before loading.

NOTE: Ensure the ramp and truck/trailer are properly rated for the weight of the machine.

NOTE: Use a ramp with no more than a 12% incline to load and unload the machine.

NOTE: Transport the machine with the scrub head in the lowered position.

NOTE: Do not lower the Orbital Scrub Head without a pad installed. Doing so will damage the Mighty-Lok® face.

NOTE: Remove the rear squeegee assembly before transporting the machine.

Two (2) tie-down points have been provided to allow the machine to be secured during transportation.

Ensure the machine is properly secured with suitable tie-down straps before transporting the machine.



Run tie down straps between the Recovery and Solution tanks

Tie down holes on both sides of the main frame

BATTERIES

WARNING: Battery posts, terminals, and related accessories contain lead and lead compounds, chemicals known to the State of California to cause cancer and reproductive harm, and during charging, strong inorganic acid mists containing sulfuric acid are involved, a chemical known to the State of California to cause cancer. Wash hands after handling. For more information go to www.P65Warnings.ca.gov.



WARNING: Batteries emit hydrogen and oxygen gas.



- Keep sparks and open flame away.
- Do not smoke near the machine
- Charge batteries in a well-ventilated area with the battery compartment open

WARNING: Do not wear jewelry when working near moving or electrical components.



CAUTION: Park and service the machine on a level surface and remove the key.

CAUTION: Always wear protective clothing, gloves and goggles when handling and charging batteries.

NOTE: All repairs must be performed by a qualified service technician using approved replacement parts.

NOTE: Failure to clean the BatteryShield® light pipe will limit the system's ability to read the water level and will reduce battery life.

NOTE: Batteries designed for automotive or marine and RV use are not suited for use in floor scrubbers.

SELECTION

The machine requires two 12 VDC Lead Acid or AGM Deep Cycle batteries designed for floor scrubber use with the following maximum dimensions:

- Width: 7 1/8 in (181 mm)
- Length: 12 15/16 in (264 mm)
- Height: 10 5/8 in (295 mm)

INSTALLATION

1. Open the Recovery Tank.
2. Use a lifting device capable of lifting and transporting the batteries safely.
3. Move the batteries into position (as shown below).
4. Connect the batteries in a series to obtain an overall voltage of 24V.
5. Fully charge the batteries before use.

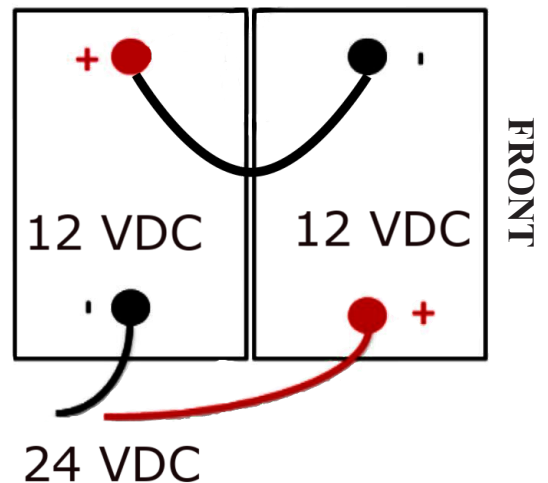
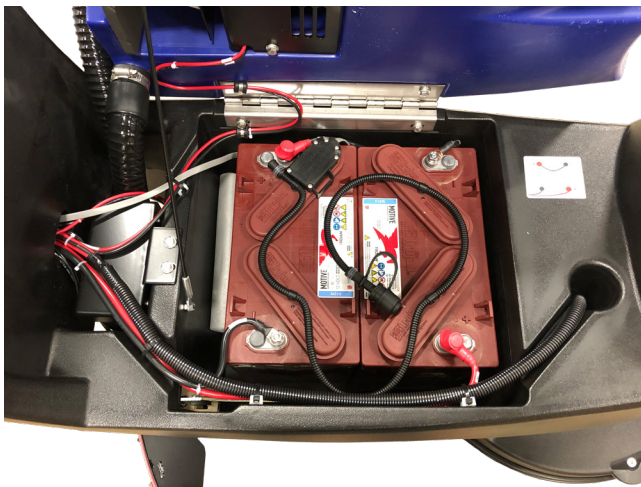

SERVICING LEAD ACID BATTERIES (NON-HYDROLINK® MODELS)

REQUIRED EQUIPMENT

- Eye protection
- Acid resistant gloves
- Distilled water
- Baking soda to neutralize acid spills

SAFETY

NEVER:

- Add acid to a battery.
- Smoke near batteries.
- Charge a frozen battery.
- Leave an acid spill unattended.
- Store batteries unless they are fully charged.
- Charge a battery when the temperature is above 122°F (50°C).
- Charge a flooded battery without securing vent caps on the cells.
- Place objects on top of batteries, which can cause a short circuit.

ALWAYS:

- Neutralize acid spills with baking soda and water.
- Use insulated tools to verify connections are tight.

WATERING

- If contact with electrolyte (sulfuric acid) occurs, flush with large amounts of water.
- Use only distilled water (tap water can contain contaminants that will damage the battery).
- Remove the caps and place them upside down to check electrolyte levels.
- For discharged or partially charged batteries, add just enough water to cover the plates.
- Fully charge the batteries.
- Add distilled water to a level of 1/8" (0.125") below the vent well.



CLEANING & INSPECTION

- Fluid on the top of a battery may mean it is being over-watered or overcharged.
- Check cleanliness and keep terminals and connectors free of corrosion.
- Clean with a solution of one cup baking soda to one gallon of water.
- Do not allow cleaning solution to get inside the battery.
- Rinse with water and dry with a clean cloth.
- Keep the area around batteries clean and dry.
- Properly secure all vent caps.
- Check battery cables and connections. Replace any damaged cables and tighten any loose connections.

SERVICING LEAD ACID BATTERIES WITH HYDROLINK® WATERING SYSTEM

1. Position the container of distilled water below the level of the top of the batteries to prevent siphoning.
2. Place the end of the watering system hose in the distilled water and squeeze the bulb to fill the system.
3. Remove the dust cover from the Hydrolink® snake connected to the batteries.
4. Connect the coupler on the Hydrolink® snake to the coupler on the watering system using the quick disconnect fittings.
5. While squeezing the hand pump, observe the flow indicator (spinning red balls). As the batteries begin to fill, the spinning of the flow indicator balls will slow. Batteries are full when the flow indicators completely stop spinning.

NOTE: Battery systems may take more than 1/2 gallon of water once the BatteryShield® light has illuminated. Failure to actuate the hand pump until the flow indicator stops spinning will result in batteries being under or unevenly serviced which will reduce battery life.

6. When the flow indicator stops, and not before, disconnect the coupler by depressing the push button on the watering system coupler.

NOTE: Leaving the watering system connected could result in the batteries being over filled. Disconnecting the watering system before the flow indicator stops spinning will result in batteries being under serviced and battery life will be reduced.

7. Replace the dust cover on the Hydrolink® snake.



BATTERYSHIELD® AUTOMATED WET BATTERY PROTECTION SYSTEM

Machines equipped with BatteryShield® technology have a sensor installed on one of the battery caps and a red LED indicator located on the Control Panel. This sensor monitors the water level in the batteries and the LED communicates to the operator that the batteries require servicing. When the BatteryShield® LED is lit, the scrub head is disabled until battery servicing has been performed.

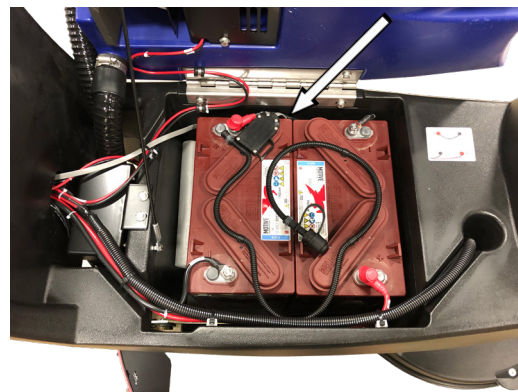

- When the key switch is turned on, the BatteryShield® system will check the water level of the batteries.
 - If the LED turns off, there is sufficient water in the batteries.
 - If the LED remains on (without flashing), the batteries require servicing and the scrub head will not run.
 - If the LED flashes intermittently, the BatteryShield® light pipe must be cleaned (instructions below).

NOTE: Failure to clean the BatteryShield® light pipe will limit the system's ability to read the water level and will reduce battery life.

- If the BatteryShield® LED indicates the need for servicing, turn off the key switch and service the batteries as described above.
- After completing the Hydrolink® watering system procedure, turn the key switch back on and verify the LED turns off.

CLEANING THE BATTERYSHIELD® SENSOR LIGHT PIPE

CAUTION: Always wear protective clothing, gloves and goggles when handling and charging batteries.

NOTE: All repairs must be performed by a qualified service technician using approved replacement parts.

1. Locate and remove the battery cap with the BatteryShield® sensor module.

NOTE: Never remove the BatteryShield® sensor from the battery cap. Doing so will cause the BatteryShield® system to function improperly.

NOTE: Take care not to damage the battery cap floats or the BatteryShield® sensor light pipe.

2. Thoroughly wipe the clear BatteryShield® light pipe with a clean rag, giving special attention to the tip.
3. With the battery cap still removed, cycle the key switch on to verify that the BatteryShield® LED remains on.
4. Turn off the key switch.
5. Carefully install the battery cap.

NOTE: Whenever the battery cap is removed, ensure the Hydrolink® snake port is fully seated in the cap when maintenance is complete.

6. Complete the Hydrolink® watering procedure described above.
7. Turn on the key switch and verify the light remains off.
8. The machine is ready for use.

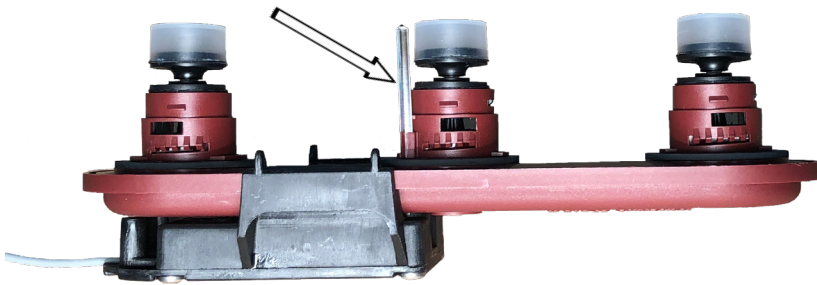

CHARGING

WARNING: Batteries emit hydrogen and oxygen gas.



- Keep sparks and open flame away.
- Do not smoke near the machine.
- Charge batteries in a well-ventilated area with the battery compartment open.

WARNING: Do not wear jewelry when working near moving or electrical components.



WARNING: Do not plug in the charger cable if wall cord or battery harness is damaged.



NOTE: Do not use an extension cord with the battery charger. This will void the charger warranty.

NOTE: Ensure battery charging and storage locations comply with OSHA and any governing agencies' standards based on your particular location and application.

NOTE: Seat assembly must remain open while charging to prevent damage to the charger power cord.

ON-BOARD CHARGING

The charger status LED's (used to indicate the charger's status while plugged in) can be viewed through the view window located on the vertical kick panel below the seat.

LED INDICATION	MEANING
GREEN flashing (2 seconds)	Charger is set for AGM batteries
YELLOW flashing (continuous)	Unsuitable battery connected or output short circuit
RED flashing (2 seconds)	Charger is set for Lead Acid batteries
RED flashing (continuous)	Safety timer exceeded or internal short circuit
Solid GREEN	The unit is fully charged
Solid YELLOW	Phase 2 of charging is in progress
Solid RED	Charging cycle has begun

CHARGER SETTINGS

SW1: Sets the current profile of the charger to the particular battery that is installed.

SW1		
DP1	DP2	APPLICATION
ON	OFF	LEAD-ACID BATTERIES
OFF	OFF	AGM FULLRIVER
OFF	ON	AGM DISCOVERY
ON	ON	GEL

SW2: Set the current level of the charger based on the amp-hour rating for the particular batteries installed.

SW2		
DP1	DP2	CHARGING CURRENT
ON	ON	15A
OFF	ON	20A
ON	OFF	25A - XCF
OFF	OFF	25A

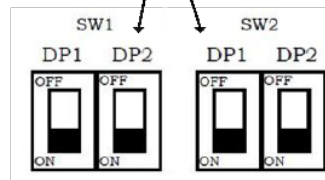
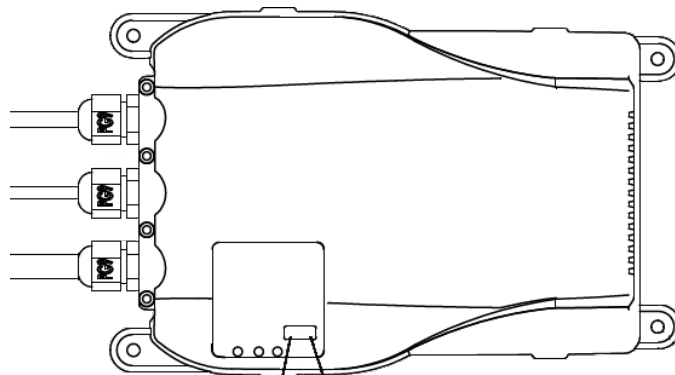

CHARGING CURRENT	BATTERY AMP HOUR RANGE (5h)	BATTERY AMP HOUR RANGE (20h)
15A	100-150 Ah	130-180 Ah
20A	120-195 Ah	150-240 Ah
25A	180-258 Ah	220-315 Ah

OFF-BOARD CHARGING

WARNING: This product can expose you to chemicals including lead and lead compounds which are known to the State of California to cause cancer and birth defects or other reproductive harm. For more information go to www.P65Warnings.ca.gov.



WARNING: Batteries emit hydrogen and oxygen gas.



- Keep sparks and open flame away.
- Do not smoke near the machine.
- Charge batteries in a well-ventilated area with the battery compartment open.

WARNING: Do not plug in the charger cable if wall cord or battery harness is damaged.



NOTE: Ensure battery charging and storage locations comply with OSHA and any governing agencies' standards based on your particular location and application.

1. Set the **Battery Type** switch to match the battery configuration of the machine.
 - Up for Lead Acid batteries.
 - Down for sealed, maintenance-free AGM batteries
2. Connect the charger to the wall outlet.
3. Connect the red plug (pictured below) to the battery harness below the control panel at the rear of the machine.

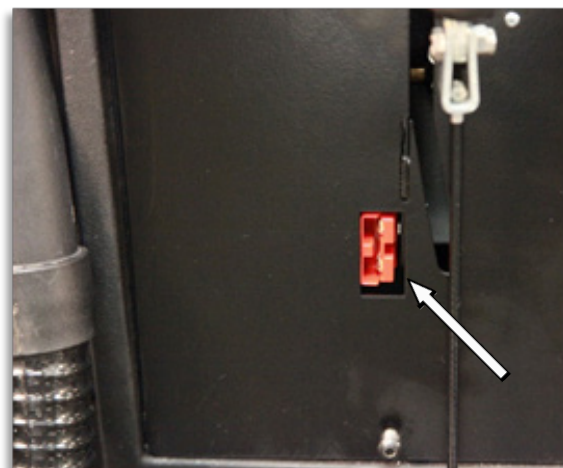

OFF-BOARD CHARGER STATUS LEDs

Primary (Green) LED:

- Blinking slowly: Batteries are below 80% of full charge.
- Blinking rapidly: Batteries are above 80% of full charge.
- Solid: Batteries are fully charged.

Fault (Red) LED:

- See the charger manual for fault information.

OPERATION MACHINE OVERVIEW

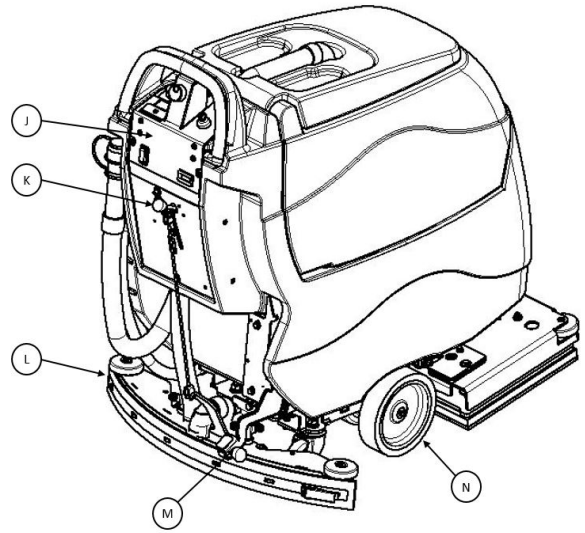
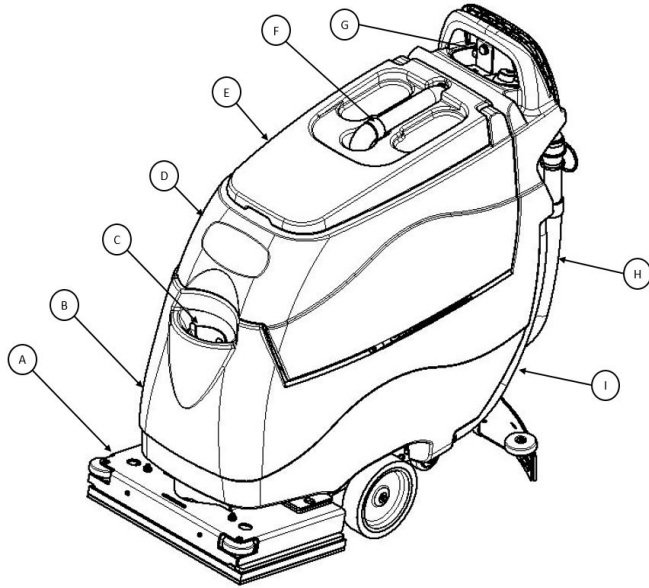

- A. SCRUB HEAD
- B. SOLUTION TANK
- C. FILL PORT
- D. RECOVERY TANK
- E. RECOVERY TANK LID

- F. RECOVERY HOSE
- G. REVERSE SWITCH
- H. RECOVERY DRAIN HOSE
- I. SOLUTION SIGHT TUBE

- J. CONTROL PANEL
- K. SQUEEGEE LIFT LEVER
- L. SQUEEGEE ASSEMBLY
- M. HEAD LIFT LEVER
- N. WHEELS

CONTROL PANEL



- A. CIRCUIT BREAKERS
- B. A/B SWITCH (DISK MODELS ONLY)
- C. BATTERYSHIELD LED (OPTIONAL)
- D. BATTERY LEVEL INDICATOR
- E. SOLUTION FLOW CONTROL

- F. DRIVE BAIL
- G. SPEED CONTROL
- H. KEY SWITCH
- I. HOUR METER (OPTIONAL)

TURNING THE UNIT ON/OFF

The key switch is located on the control panel. When the machine is not in use, remove the key and store it in a secure location.

CIRCUIT BREAKERS

The circuit breakers on the control panel protect the components from high amp-draw. In particular, the scrub head circuit will draw too many amps when overloaded by improper application setup. Solution flow, floor surface, and down-pressure should be considered when operating the machine (example: high down-pressure on a rough floor with no solution flow will overload the circuit). Repeatedly tripping the breaker will cause the need for replacement.

BATTERY POWER LEVEL & FAULT INDICATOR

When switched to the ON position, the Battery Power Level Indicator illuminates indicating the battery charge level. A full charge is indicated when all LEDs are lit. As the power level decreases, the LEDs go out from right to left.

When the battery charge is depleted, the last red LED will flash and the brush motor will turn off. The vacuum and traction drive will continue to function allowing final water recovery and transport to the charging station.

NOTE: Using AGM battery-equipped units after the last yellow LED goes out can reduce the life of the batteries.

NOTE: After a full charge, operate the machine for at least 30 minutes before recharging the batteries again. Do not leave the batteries discharged overnight.

MACHINE ERROR CODES



The battery needs charging or there is a bad connection to the battery. Check the connections to the battery. If the connections are good, try charging the battery.



There is an open connection to the traction motor. Check all connections between the motor and the control system.



There is a short circuit in the traction motor system. Check all connections between the motor and the control system.



The control system is being inhibited from driving.



Inspect Throttle System. Ensure that the throttle is in the rest position before switching on the machine. Check all associated connectors and wiring.



A control system trip is indicated. Make sure that all connections are secure.



Inspect the Brake System. Ensure the brake is functioning properly. Check all associated connectors and wiring.



Excessive voltage has been applied to the control system. This is usually caused by a poor battery connection. Check the battery connections.

DRIVE SYSTEM (TRACTION MODELS)

1. Turn the machine on using the key switch located on the right side of the steering column.
2. Set the desired maximum speed using the Speed Control selector on the Control Panel.
3. Maintain control of the machine at all times during operation.
4. Depress the Bail to engage the scrub head and drive system (on applicable models).
5. Depress the Reverse Button to drive the machine backwards (on applicable models).

OPTIONAL SCRUBSMART TELEMETRY SYSTEM

The 11-gallon autoscrubber can be ordered with our ScrubSmart telemetry system, powered by Trackunit®. This system is used for asset tracking and reporting. For more information on this system and its reporting capabilities, contact your distributor or Pacific Floorcare Customer Service.

Telemetry-equipped machines have a keypad mounted on the upper right side of the control panel. After turning on the key switch, enter the operator code. **Failure to enter a valid operator code will prevent the machine from functioning.** Operator codes are generated and administered by your Pacific Distributor or your company's management.



SOLUTION DISTRIBUTION

FILLING THE SOLUTION TANK

Use liquid detergent in the concentration and manner specified by the manufacturer for a 11-gallon solution tank. Excess foam will damage the vacuum motor. In addition to properly-mixed low-foam detergent, use a small amount of de-foaming liquid in the recovery tank. Never use pure acids.

1. Add water and cleaning agent via the fill port located at the front of the machine. Water should not exceed 120°F (50°C).
2. Monitor the level of the solution through the sight tube located at the rear of the machine.
3. To drain the solution tank, slide the sight tube off of the upper fitting and lower the tube into drain or mop sink.



SOLUTION FLOW

Solution flow is controlled by the Solution Flow Control located on the Control Panel. When the Scrub Head is lowered, solution is delivered at a rate of 0 - 0.5 gpm (0 - 1.9 lpm) based upon the Solution Flow setting and the speed of the machine (flow rate increases or decreases with machine speed to prevent over/under distribution).



INSPECTION & CLEANING

To clean out the solution tank in the case of excessive debris:

1. Close the shutoff valve (located under the machine).
2. Remove the filter bowl and screen (located forward of the shutoff valve).
3. Open the shutoff valve and allow the tank to drain.
4. Rinse the solution tank thoroughly.
5. Install the filter bowl and screen.

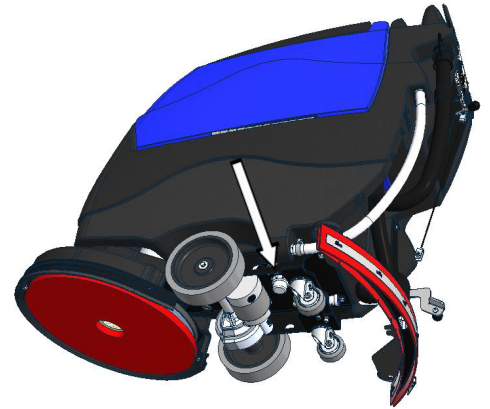

SCRUB HEAD

HEAD LIFT

1. Depress the foot lever (located at the lower right rear corner of the machine) and shift it to the right.
2. Once clear of the notch, allow the lever to rise while the head lowers into the operating position.
3. Disk machines are equipped with a self-adjusting shroud and bristle skirt that virtually eliminates over-spray.



Scrub Head Raised



Scrub Head Lowered

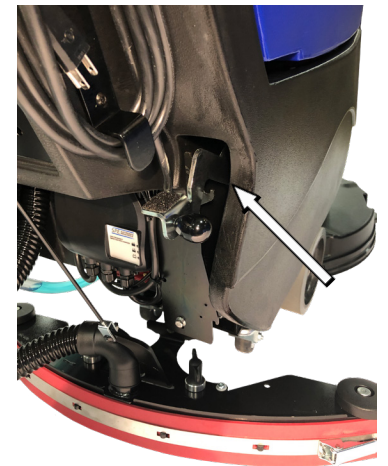

**Scrub Head Lowered
Heavy Down Pressure**

SELECTING DOWN PRESSURE

- Standard: For daily cleaning of normal soils.
- Heavy: For toughest soils or chemical-free finish removal.

ORBITAL SCRUB HEAD & CHEMICAL-FREE FINISH REMOVAL

NOTE: Do not operate the Orbital Scrub Head without a pad installed. Operating the head without a pad will damage the Mighty-Lok® face.

NOTE: Use of caustic, high ph, or degreasing chemicals can decrease the service life of components, including the orbital head bearing.

STANDARD OPERATION

1. Align the corners of the pad to the corners of the aluminum plate with Mighty-Lok® face and press to attach.
2. Lower the scrub deck onto the pad.
3. Ensure the pad is properly aligned front-to-back and right-to-left. Water should drip directly onto the top of the pad.

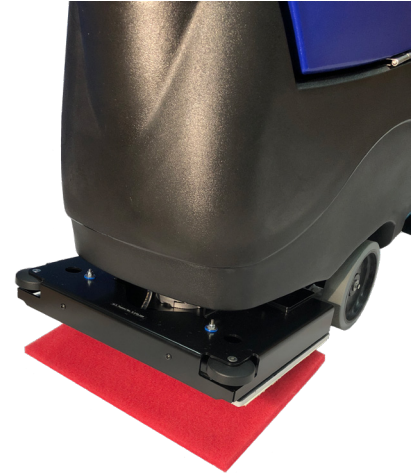

CHEMICAL-FREE FINISH REMOVAL (CFR) PAD ASSEMBLY & OPERATION

In addition to the traditional cleaning pad, a specialized surface preparation pad is required for chemical-free finish removal. The standard red scrub pad acts as a “backer” and compensates for variances in the floor.

1. Place the black retainer pad 2” back from the front of the red scrub pad.
2. Align the maroon CFR pad with the red scrub pad.
3. Ensure the pads are aligned so that the black pad is justified towards the back of the machine, so that the gap described in Step 1 is towards the front of the machine.
4. Install the pads in accordance with the instructions above for standard operation.
5. Fill the Solution Tank with clean water.
6. Set the Solution Flow to the medium setting. Adjust as needed to obtain the optimum finish removal using the least amount of water for effective rinsing.
7. Set the Speed Control to the medium setting.
8. Lower the Scrub Head to the Heavy Down Pressure setting.

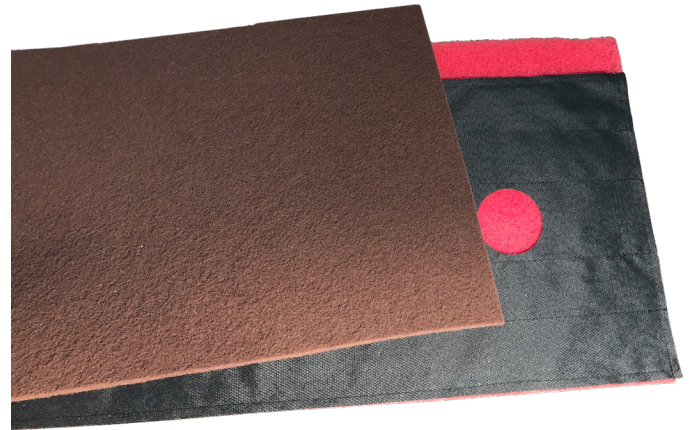

DISK SCRUB HEAD

DISK INSTALLATION

NOTE: Do not operate the Disk Scrub Head without a pad installed on the pad driver. Operating the head without a pad will damage the floor.

1. Turn the key switch on and rotate the speed control knob to the full slow position.
2. Place the pad drivers or brushes on the floor in front of the scrub head.
3. Push or drive the machine into position centering the scrub head over the pad drivers or brushes.
4. Lower the scrub deck onto the pad drivers or brushes.

NOTE: When properly aligned, the scrub deck shroud bristle skirt should almost be touching the floor.

5. Quickly squeeze and release the Bail to engage the pad driver or brushes.

NOTE: If the pad drivers or brushes do not quickly engage, return to step two and try again.



DISK REMOVAL

1. Toggle the “Brush On/Off” switch to position “A” for 1 second and then immediately to position “B”. The brush will spin in position “A” and abruptly stop in position “B”, releasing the pad drivers.
2. Remove the center lock fitting by squeezing the wires inward and pulling the center lock away.
3. To connect the cleaning pad to the drivers, center the pad on the driver, squeeze the center lock wires inward, and press down (tab side first). Press the pad and release the wires so that they lock in place.

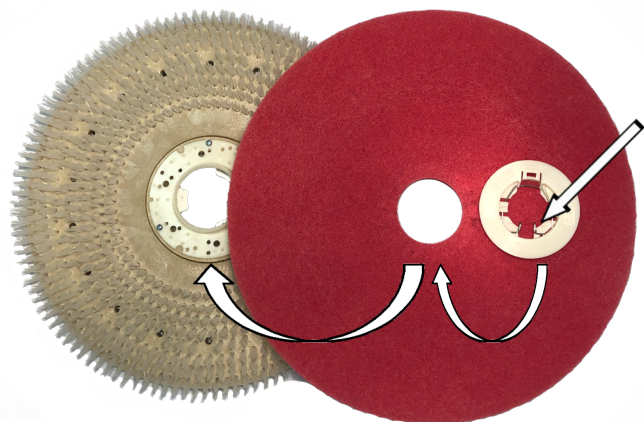

RECOVERY SYSTEM

RECOVERY TANK

To drain and rinse the recovery tank:

1. Remove the Recovery Drain Hose from the holder and lower the end into the drain location.
2. Remove the press-fit cap from the Recovery Drain Hose, squeezing the restriction collar to control the flow.
3. As the tank drains, lift the Recovery Tank to the open position.
4. Using clean water, thoroughly clean and rinse out any sediment in the Recovery Tank.

NOTE: Periodically use cleaner and sanitizer with a cloth or sponge to prevent mold and mildew.

5. Inspect and vacuum the mesh filter screen around the ball float system.
6. Leave the lid open to dry.



SQUEEGEE SYSTEM

Squeegee Blades and system should be inspected and maintained regularly to achieve peak machine performance.

REMOVAL & INSTALLATION

Install: Align the slots in the squeegee assembly with the easy-grip knobs, attach the vacuum hose, and tighten the knobs.

Remove: Loosen the easy-grip knobs, remove the vacuum hose, and remove the assembly.

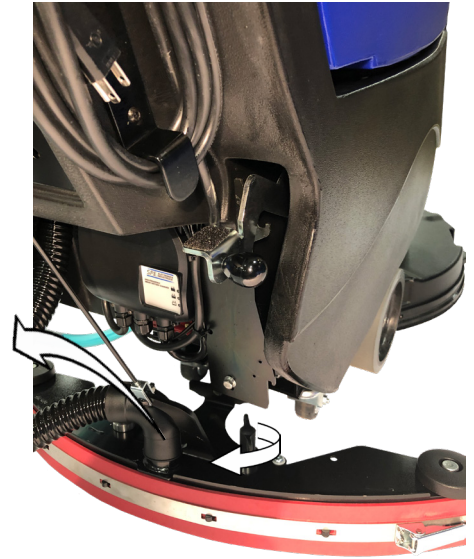

SQUEEGEE USE

With the Key Switch turned on, lower the Squeegee Lift Lever to activate the Vacuum Motor. Raising the Squeegee Lift Lever will deactivate the Vacuum Motor to shut off after a 10 second delay. This delay ensures all of the recovered water is pulled into the Recovery Tank.



SQUEEGEE ADJUSTMENT

Improper adjustment of the squeegee blades will reduce the systems ability to properly pick up water. The leading edge of the rear squeegee blade should contact the floor at a 45° angle (similar to the image shown below). The height of the squeegee system is adjusted using the two cap head screws located next to the easy-grip knobs. Raise (by turning the screws clockwise) or lower (by turning the screws counter-clockwise) until the proper blade deflection is achieved. When the system is adjusted properly, the small gray wheels on the squeegee system should be approximately 1/32" off of the floor.



INSPECTION & CLEANING

1. Inspect both squeegee blades. Blades edges are considered worn if the edge is not clearly defined or if the edge is worn halfway through the thickness of the blade. Blades can be flipped and rotated to use all four edges.
2. Thoroughly clean the blades, frame, and neck of any debris.

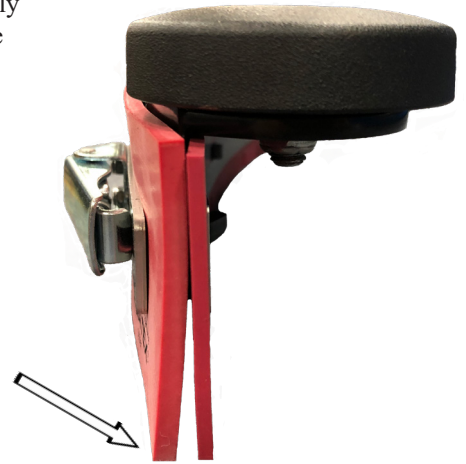

SQUEEGEE BLADE REPLACEMENT

1. Release the over-center latch and slide the band clamp off the hook on the other side.
- NOTE:** Blades can be flipped and rotated so as to use all four edges.
2. Blade installation is the reverse of the removal.



RECOMMENDED MAINTENANCE

SYSTEM	DAILY	WEEKLY	MONTHLY	BIANNUALLY
CONTROL PANEL				
INSPECT CONTROLS AND HARDWARE FOR SECURITY & SERVICEABILITY	X			
VERIFY PROPER OPERATION OF ALL CONTROLS	X			
SOLUTION DISTRIBUTION				
VERIFY SOLUTION FLOW & ADJUSTMENT OPERATION	X			
CLEAN AND INSPECT INLINE FILTER			X	
FLUSH TANK WITH FRESH WATER			X	
SCRUB DECK				
RINSE BRUSHES & PADS	X			
RINSE & DRY SCRUB DECK	X			
CLEAN MOTOR VENTS			X	
INSPECT ISOLATORS <i>*(ORBITAL ONLY)</i>				X
INSPECT LIFT LINKAGE & PIVOT BLOCKS				X
RECOVERY SYSTEM				
RINSE & AIR DRY RECOVERY TANK	X			
VERIFY DRAIN HOSE CAP IS SEALED TIGHT WHEN INSTALLED	X			
INSPECT LID SEAL		X		
CLEAN & SANITIZE RECOVERY TANK			X	
BATTERIES AND CHARGER				
INSPECT TERMINALS & CABLES FOR SECURITY, CORROSION & DAMAGE			X	
SERVICE LEAD ACID BATTERIES <i>*(IF EQUIPPED)</i>		X		
CLEAN ON-BOARD CHARGER VENTS <i>*(IF EQUIPPED)</i>			X	
CLEAN BATTERYSHIELD® LIGHT PIPE <i>*(IF EQUIPPED)</i>				X
PERFORM BATTERYSHIELD® OPERATIONAL CHECK <i>*(IF EQUIPPED)</i>				X
SQUEEGEE ASSEMBLY				
CLEAN & INSPECT SQUEEGEE ASSEMBLY & BLADES	X			
INSPECT VACUUM HOSE		X		
CHASSIS AND UNDERCARRIAGE				
CLEAN AND INSPECT WHEELS & CASTERS			X	
CLEAN AND INSPECT LINKAGES, CHASSIS & HARDWARE			X	
CLEAN AND INSPECT VISIBLE WIRES FOR DAMAGE & SECURITY				X
GENERAL				
INSPECT FOR LOOSE HARDWARE AND TIGHTEN AS NECESSARY			X	

PAGE INTENTIONALLY BLANK

RECOMMENDED SERVICE PARTS

PART NUMBER	DESCRIPTION	DIAGRAM	WEAR ITEM	S-20 PAD ASSIST DISK	S-20 TRACTION DISK	S-20 ORBITAL	S-24XM	OPTIONAL
903046	BELT, V-GROOVE, STRETCH	SCRUB HEAD	X				X	
850701	BLADE, FRONT, 30 INCH	SQUEEGEE	X	X	X	X	X	
850703	BLADE, FRONT, 30 INCH, URETH (OPTL)	SQUEEGEE	X	X	X	X	X	
850704	BLADE, REAR, 30 IN, URETH (OPTIONAL)	SQUEEGEE	X	X	X	X	X	
850702	BLADE, REAR, 30 INCH	SQUEEGEE	X	X	X	X	X	
850905	BRUSH CARBON KIT 4 PC 855201	SCRUB HEAD	X		X			
850906	BRUSH CARBON KIT 4 PC 855204 & 875201	SCRUB HEAD	X			X		
870919	BRUSH KIT REPL FOR TRANSAXLE 859201	FRAME	X		X	X	X	
870909	BRUSH, GRIT, 12 INCH	SCRUB HEAD	X				X	
850903	BRUSH, GRIT, 20 INCH	SCRUB HEAD	X		X			
870908	BRUSH, NYLON, 12 INCH	SCRUB HEAD	X				X	
850902	BRUSH, NYLON, 20 INCH	SCRUB HEAD	X		X			
870902	BRUSH, POLY, 12 INCH	SCRUB HEAD	X				X	
850901	BRUSH, POLY, 20 INCH	SCRUB HEAD	X		X			
852401	CABLE, LIFT, CLEVIS	CONTROLS		X	X	X	X	
911622	CIRCUIT BREAKER, 30 AMPS	CONTROLS		X	X	X	X	
852002	CLAMP, OVER-CENTER, BAND	SQUEEGEE		X	X	X	X	
912401	CONTACTOR, 24V, 100A	ELECTRONICS		X	X	X		
912402	CONTACTOR, 24VDC, 70A	ELECTRONICS		X	X	X		
875901	DRIVER, PAD, 12INCH, BRISTLE	SCRUB HEAD	X				X	
855901	DRIVER, PAD, 20INCH, BRISTLE	SCRUB HEAD	X		X			
843319	FILTER, SCREEN, BOWL	FRAME	X	X	X	X	X	
223370	FLOAT, SHUTOFF	RECOVERY TANK	X	X	X	X	X	
853309	FOAM NOISE SHORT	RECOVERY TANK	X	X	X	X	X	
853305	FOAM, NOISE, VACUUM	RECOVERY TANK	X	X	X	X	X	
858202	FOAM, SPACER, BATTERY	BATTERIES	X	X	X	X	X	
873314	GASKET, FOAM, VACUUM	RECOVERY TANK	X	X	X	X	X	
853803	GUIDE, DRIVER	SCRUB HEAD	X		X		X	
873802	GUIDE, DRIVER, RH	SCRUB HEAD	X				X	
873801	GUIDE, PAD, PLASTIC	SCRUB HEAD	X				X	
853804	GUIDE, PAD, PLASTIC	SCRUB HEAD	X		X			
854104	HOSE DRAIN CAPPED CHEM RESIST	RECOVERY TANK	X	X	X	X	X	

RETURN TO
TABLE OF
CONTENTS

RECOMMENDED SERVICE PARTS

PART NUMBER	DESCRIPTION	DIAGRAM	WEAR ITEM	S-20 PAD ASSIST DISK	S-20 TRACTION DISK	S-20 ORBITAL	S-24XM	OPTIONAL
854105	HOSE SQUEEGEE S-20 CHEM RESIST	RECOVERY TANK	X	X	X	X	X	
854101	HOSE, DRAIN, CAPPED	RECOVERY TANK	X	X	X	X	X	
854102	HOSE, SQUEEGEE, 90 CUFF	RECOVERY TANK	X	X	X	X	X	
854103	HOSE, VACUUM, 1.5INCH	RECOVERY TANK	X	X	X	X	X	
854302	HUB, DRIVER, BRUSH	SCRUB HEAD	X		X			
874305	HUB, PULLEY, MACH FLAT	SCRUB HEAD	X				X	
874306	HUB, PULLEY, MACH GROOVED	SCRUB HEAD	X				X	
855012	KEY, REPLACEMENT, SCRUBBER	CONTROLS	X	X	X	X	X	
855015	ASSY, CASTER 3 INCH REPLACEMENT	FRAME	X	X	X	X	X	
875019	ASSY, SKIRT REPLACEMENT (ITEMS 6 - 10)	SCRUB HEAD	X				X	
855014	ASSY, VALVE SCRUBBER REPLMNT	FRAME		X	X	X	X	
855010	ASSY, BEARING, REPLMNT, ORBITAL	SCRUB HEAD	X			X		
855205	MOTOR, VAC, 24VDC, PERIPH	RECOVERY TANK		X	X	X	X	
555901	PAD 12" BLACK STRIP CASE 5	SCRUB HEAD	X				X	
555941	PAD 12" RED SCRUB CASE 5	SCRUB HEAD	X				X	
555951	PAD 12" WHITE POLISH CASE 5	SCRUB HEAD	X				X	
555908	PAD 14"X20" BLACK STRIP CASE 5	SCRUB HEAD	X			X		
555928	PAD 14"X20" MAROON CFR CASE 10	SCRUB HEAD	X			X		
555948	PAD 14"X20" RED SCRUB CASE 5	SCRUB HEAD	X			X		
555968	PAD 14"X20" TURF CASE 4	SCRUB HEAD	X			X		
555958	PAD 14"X20" WHITE POLISH CASE 5	SCRUB HEAD	X			X		
555906	PAD 20" BLACK STRIP CASE 5	SCRUB HEAD	X	X	X			
555926	PAD 20" MAROON CFR CASE 10	SCRUB HEAD	X	X	X			
555946	PAD 20" RED SCRUB CASE 5	SCRUB HEAD	X	X	X			
555966	PAD 20" TURF CASE 4	SCRUB HEAD	X	X	X			
555956	PAD 20" WHITE POLISH CASE 5	SCRUB HEAD	X	X	X			
875903	PAD, MIGHTYLOK ADH UNIVERSAL	SCRUB HEAD	X			X		
855909	PAD, RETAINER, 12X20	SCRUB HEAD	X					
857009	PLUNGER BALL PRESS-IN	SCRUB HEAD	X	X	X		X	
857003	PUMP ASSY HAND HYDROLINK	BATTERIES	X					X
911685	RELAY, 24VDC, BATTERYSHIELD	ELECTRONICS		X	X			
858503	SKIRT, BRISTLE	SCRUB HEAD	X		X		X	

RECOMMENDED SERVICE PARTS

PART NUMBER	DESCRIPTION	DIAGRAM	WEAR ITEM	S-20 PAD ASSIST DISK	S-20 TRACTION DISK	S-20 ORBITAL	S-24XM	OPTIONAL
878504	STRAP, GROUNDING, STATIC	SQUEEGEE LINK	X	X	X	X	X	
911647	SWITCH, KEY	CONTROLS		X	X	X	X	
911649	SWITCH, ROCKER, AUTO ON-OFF	CONTROLS			X	X	X	
911653	SWITCH, ROUND, ON – MOM	CONTROLS			X	X	X	
911682	SWITCH, SNAP, BENT LEVER	FRAME		X	X	X	X	
911646	SWITCH, SNAP, WITH ROLLER	CONTROLS		X	X	X	X	
879002	TUBE & PUMP ASSY (NOT SHOWN, OPTIONAL)	BATTERIES	X	X	X	X	X	
859003	TUBE, SIGHT, REPLACEMENT	SOLUTION TANK	X	X	X	X	X	
859402	VALVE SOLENOID 24V NONADJ	FRAME		X	X	X	X	
849709	WHEEL, 2 OD, .31 ID	SQUEEGEE LINK	X	X	X	X	X	
859702	WHEEL, BRG, 8 INCH	FRAME	X	X				
855022	KIT-GUIDE WHEEL REPLACEMENT, ANTI RATTLE	SCRUB HEAD	X	X	X	X		
859704	WHEEL, TRACTION, 200MM	FRAME	X		X	X	X	

PAGE INTENTIONALLY BLANK

TROUBLESHOOTING GUIDE

ISSUE	POTENTIAL CAUSE	PROPOSED SOLUTION
INSUFFICIENT WATER TO SCRUB HEAD	SOLUTION FLOW SETTING IS TOO LOW	ADJUST SOLUTION CONTROL
	SOLUTION TANK IS EMPTY	ADD WATER/SOLUTION TO THE TANK
	INLINE SOLUTION FILTER IS CLOGGED	REMOVE AND CLEAN THE FILTER
	SOLUTION TUBE IS CLOGGED, KINKED, OR DAMAGED	INSPECT TUBES
	SOLUTION SHUT OFF VALVE IS CLOSED	OPEN VALVE
	SOLUTION SOLENOID VALVE MAY BE FAULTY	VERIFY OPERATION AND REPLACE IF NECESSARY
POOR WATER RECOVERY	RECOVERY TANK IS FULL	EMPTY RECOVERY TANK
	DIRTY OR WORN SQUEEGEE BLADES	INSPECT AND ROTATE OR REPLACE AS REQUIRED
	RECOVERY HOSE LOOSE OR DAMAGED	INSPECT AND REPAIR
	RECOVERY HOSE OR SQUEEGEE ASSEMBLY HAS AN OBSTRUCTION	CLEAR OBSTRUCTIONS FROM RECOVERY SYSTEM
	SQUEEGEE ASSEMBLY MAY BE OUT OF ADJUSTMENT	ADJUST AS NECESSARY
	STUCK OR DAMAGED BALL FLOAT	INSPECT AND REPAIR/REPLACE
	RECOVERY TANK LID IS NOT SEALING PROPERLY	INSPECT RECOVERY LID GASKET. REPAIR OR REPLACE IF NEEDED
	DRAIN HOSE CAP IS NOT INSTALLED PROPERLY	INSTALL DRAIN HOSE SECURELY
	LOW BATTERY VOLTAGE	CHARGE BATTERIES
MACHINE WILL NOT TURN ON	FAULTY KEY SWITCH	DIAGNOSE AND REPLACE
	DISCHARGED BATTERIES	CHARGE BATTERIES
	LOOSE OR DAMAGED WIRE	REPAIR
MACHINE NOT CLEANING FLOOR PROPERLY	WORN PAD OR BRUSH	INSPECT AND REPLACE AS REQUIRED
	WRONG PAD OR BRUSH FOR APPLICATION	CONTACT YOUR LOCAL DISTRIBUTOR FOR RECOMMENDED APPLICATION
	INSUFFICIENT CLEANING SOLUTION FOR APPLICATION	ADJUST THE MIXTURE AS REQUIRED
EXCESSIVE FOAM IN RECOVERY TANK	IMPROPER DETERGENT TYPE	USE A LOW-FOAM DETERGENT OR ADD A DEFOAMING AGENT TO THE RECOVERY TANK. READ ALL CHEMICAL LABELS THOROUGHLY BEFORE USE
VACUUM MOTOR WILL NOT RUN	SQUEEGEE LIFT LEVER IS STILL RAISED	LOWER SQUEEGEE LEVER
	VACUUM RELAY MAY BE FAULTY	CONTACT SERVICE TECHNICIAN TO TROUBLESHOOT AND ISOLATE
	VACUUM SWITCH OR WIRING MAY BE FAULTY	CONTACT SERVICE TECHNICIAN TO TROUBLESHOOT AND ISOLATE
VACUUM MOTOR WILL NOT TURN OFF	STILL IN DELAY MODE	ALLOW 10 SECONDS FOR VACUUM TO SHUT DOWN
	VACUUM RELAY MAY BE FAULTY	CONTACT SERVICE TECHNICIAN TO TROUBLESHOOT AND ISOLATE

TROUBLESHOOTING GUIDE

ISSUE	POTENTIAL CAUSE	PROPOSED SOLUTION
SCRUB HEAD WILL NOT RUN	SCRUB HEAD IS STILL RAISED	LOWER SCRUB HEAD
	BATTERYSHIELD® LED IS ILLUMINATED AND HAS DISABLED THE SCRUB HEAD (IF EQUIPPED)	SERVICE THE BATTERIES
	BATTERIES ARE DISCHARGED BELOW THRESHOLD VOLTAGE	CHARGE BATTERIES
	BRUSH MOTOR CIRCUIT BREAKER HAS TRIPPED	SEE NEXT TOPIC ON THIS TABLE
	SCRUB HEAD LIFT ARM SWITCH MAY BE STUCK OR FAULTY	INSPECT AND REPAIR SWITCH AS REQUIRED
	TRIGGER SWITCH IN HANDLE MAY BE FAULTY	INSPECT AND REPAIR AS REQUIRED
	SOLUTION SOLENOID VALVE MAY HAVE AN INTERNAL SHORT	DISCONNECT WIRES FROM SOLENOID VALVE AND TRY RUNNING THE SCRUB HEAD AGAIN. REPLACE SOLENOID IF REQUIRED
	BATTERYSHIELD® RELAY MAY BE FAULTY (IF EQUIPPED)	CONTACT SERVICE TECHNICIAN TO TROUBLESHOOT AND ISOLATE
SCRUB HEAD CIRCUIT BREAKER IS TRIPPED	INADEQUATE SOLUTION FOR APPLICATION	INCREASE SOLUTION TO SCRUB HEAD
	SCRUB HEAD IS SET TO HEAVY DOWN PRESSURE	REDUCE DOWN PRESSURE SETTING
	PAD IS TOO AGGRESSIVE FOR APPLICATION	CONTACT YOUR LOCAL DISTRIBUTOR FOR RECOMMENDED APPLICATION
	FAULTY OR SHORTED WIRE	REPAIR
	WEAK CIRCUIT BREAKER	CONTACT SERVICE TECHNICIAN TO TROUBLESHOOT AND ISOLATE. BREAKER SHOULD NOT TRIP BELOW ITS STATED RATING
MACHINE WILL NOT DRIVE	CIRCUIT BREAKER MAY BE TRIPPED	INSPECT AND RESET. IF PROBLEM PERSISTS CONTACT SERVICE TECHNICIAN
	BATTERY METER IS FLASHING A FAULT CODE	REFERENCE FAULT CODE AND TROUBLESHOOT AS REQUIRED
	BATTERIES DISCHARGED TOO LOW	CHARGE BATTERIES
	SPEED CONTROL KNOB TURNED ALL THE WAY DOWN	INCREASE SPEED SETTING
	FAULTY CONTROLLER	CONTACT SERVICE TECHNICIAN TO TROUBLESHOOT AND ISOLATE
	FAULTY WIRING	CONTACT SERVICE TECHNICIAN TO TROUBLESHOOT AND ISOLATE
RUN TIME IS SHORT	BATTERIES ARE LOW ON WATER (LEAD ACID ONLY)	SERVICE BATTERIES
	CHARGER IS NOT SET PROPERLY FOR BATTERY TYPE	SET CHARGER TO BATTERY SPECIFICATIONS
	SCRUB HEAD IS IN HEAVY DOWN PRESSURE	REDUCE SCRUB HEAD PRESSURE
	BATTERY CHARGER IS NOT ABLE TO FINISH CHARGE CYCLE	CONFIRM A STEADY GREEN LED AFTER THE CHARGE CYCLE (BEFORE UNPLUGGING FROM THE OUTLET)
	BATTERIES ARE DEFECTIVE OR AT THE END OF THEIR LIFE	CONTACT SERVICE TECHNICIAN TO TROUBLESHOOT AND ISOLATE

- 1 If the scrub head is not working when lowered, be aware that BatteryShield® intentionally disables the scrub head when the batteries need water. Refer to the BatteryShield® Automatic Wet Battery Protection System portion of this manual.
2. For machines equipped with BatteryShield®, refer to the BatteryShield® Automatic Wet Battery Protection System portion of this manual before proceeding.
3. If a yellow LED is flashing on the battery charger, verify continuity between the charger and the batteries. Refer to the On-Board Charger section of this manual.
4. A circuit breaker is designed to prevent overloading a component/system. If a circuit breaker continues to trip, verify the system is not being overloaded or that the wiring is not damage.

FRAME ASSEMBLY ALL TRACTION MODELS

ITEM	QTY	PART NUMBER	DESCRIPTION
1	1	853202	FRAME, SCRUBBER, 20 TRACT
2	3	962269	SCREW, HEX, .31-18 X .75, SS
3	3	980094	WASHER, SPLIT LOCK, .31, SS
4	3	W243D	WASHER, FLAT, 5/16, SS
5	1	859201	TRANSAXLE, 24VDC, 20 IN
6	1	870919	BRUSH KIT REPL FOR TRANSAXLE 859201
7	1	855206	MOTOR REPL FOR TRANSAXLE 859201
8	2	850807	BRACKET, RETAINING, TRANS
9	6	W189D	SCREW, HEX, 1/4-20 X .75, SS, PATCH
10	6	920011	NUT, NYLOCK, 1/4-20, ZINC
11	2	859704	WHEEL URETHANE 200MM
12	2	847306	RING, RETAINING, EXT, .75
13	4	980780	WASHER, KEYS
14	2	915003	KEY, SQ, .188 X 1.31
15	2	980106	WASHER, FLAT, .25ID, 1.0OD, .12THK, SS
16	2	980002	WASHER, LOCK, SPLIT, .25
17	2	964008	SCREW, HEX, M6 X 25, SS, PATCH
18	2	857502	RIG CASTER 3INCH WITH AXLE
19	2	859709	WHEEL CASTER 3INCH
20	2	855015	ASSY CASTER 3 INCH REPLACEMENT
21	3	980079	WASHER, FLAT, .5, ZINC
22	2	980019	WASHER .50INCH SPLIT LOCK
23	2	920022	NUT HEX .50-13 ZINC
24	1	855014	ASSY VALVE SCRUBBER REPLMNT
25	1	859402	VALVE SOLENOID 24V NONADJ
26	4	S453P	CLAMP, HOSE, WORM
27	1	224130 - 3.75"	HOSE, 1/2" DIA X 3.75" LONG
28	1	843319	FILTER, SCREEN, BOWL
29	1	224130 - 1.56"	HOSE, 1/2" DIA X 1.56" LONG
30	1	224130 - 9.50"	HOSE, 1/2" DIA X 9.50" LONG
31	1	853301	FITTING, REDUCER, BM08, BM04
32	1	204179 - 19.0"	HOSE, 1/4" DIA X 12.50" LONG
33	2	853802	GUIDE, SPACER, ROUND
34	2	962279	SCREW, SOCKET CAP, .31X1.0, SS
35	2	920012	NUT, NYLOCK, 5/16-18, ZINC
36	1	911682	SWITCH, SNAP, BENT LEVER
37	2	W385D	NUT, NYLOCK, #4-40, ZINC
38	4	980682	WASHER, FLAT, #4, ZINC
39	2	962273	SCREW, PAN, #4-40 X .88, ZINC
40	2	873804	GROMMET .50ID .81HOLE .25THK
41	1	858304	SPRING, EXTENSION

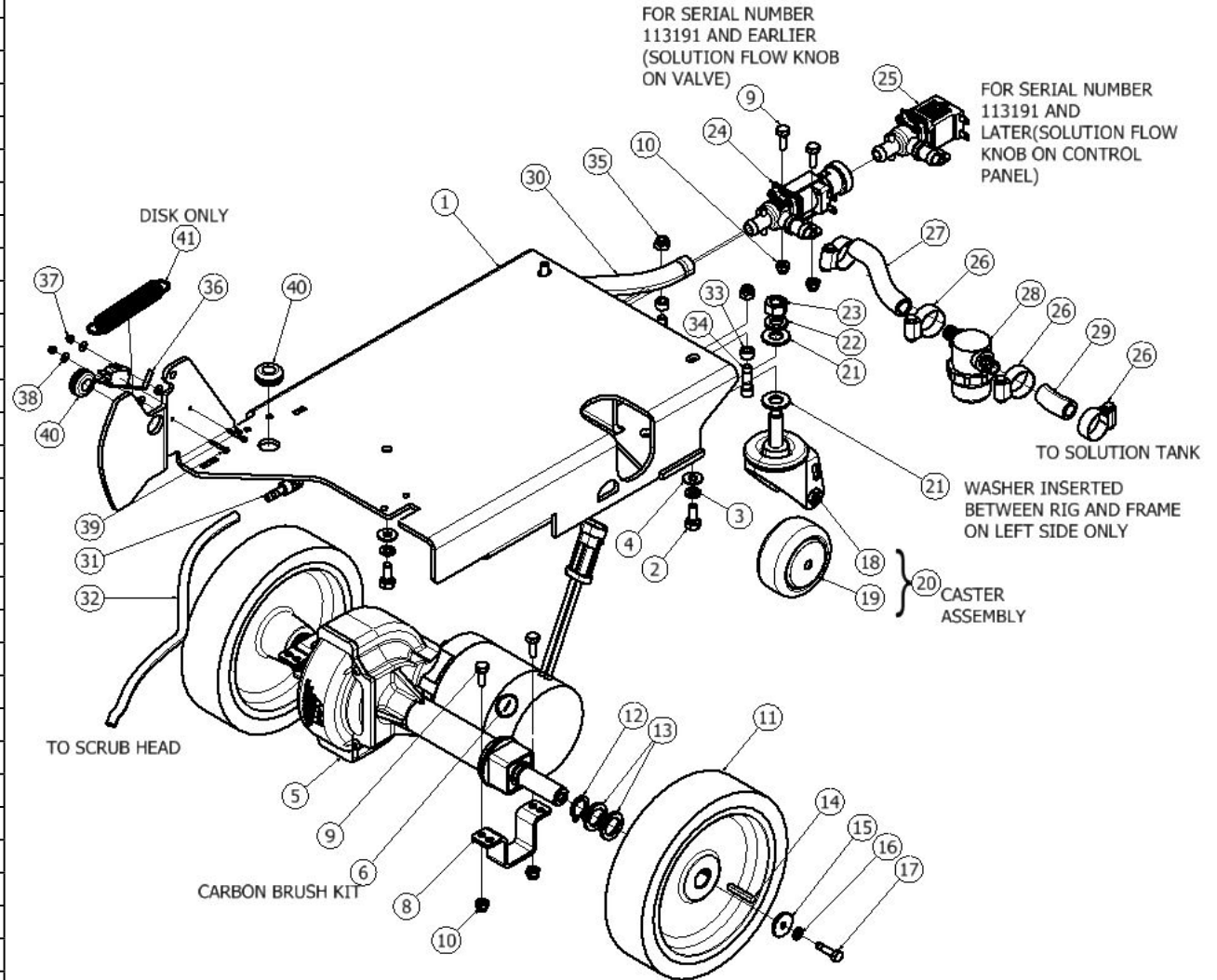

RETURN TO
TABLE OF
CONTENTS

FRAME ASSEMBLY PAD ASSIST MODELS

ITEM	QTY	PART NUMBER	DESCRIPTION
1	1	853201	FRAME, SCRUBBER, 20 BA
2	2	859702	WHEEL, BRG, 8 INCH
3	2	W502D	NUT, NYLOCK, 1/2-13, THIN, ZINC
4	2	857502	RIG CASTER 3INCH WITH AXLE
5	2	859709	WHEEL CASTER 3INCH
6	2	855015	KIT CASTER 3 INCH REPLACEMENT
7	2	980079	WASHER, FLAT, .5, ZINC
8	2	980019	WASHER .50INCH SPLIT LOCK
9	2	920022	NUT HEX .50-13 ZINC
10	1	855014	KIT VALVE SCRUBBER REPLMNT
11	2	W189D	SCREW, HEX, 1/4-20 X .75, SS, PATCH
12	2	920011	NUT, NYLOCK, 1/4-20, ZINC
13	1	224130 - 9.50"	HOSE, 1/2" DIA X 9.50" LONG
14	1	853301	FITTING, REDUCER, BM08, BM04
15	1	204179 - 17.0"	HOSE, 1/4" DIA X 12.50" LONG
16	4	S453P	CLAMP, HOSE, WORM
17	1	224130 - 3.75"	HOSE, 1/2" DIA X 3.75" LONG
18	1	843319	FILTER, SCREEN, BOWL
19	1	224130 - 1.56"	HOSE, 1/2" DIA X 1.56" LONG
20	2	853802	GUIDE, SPACER, ROUND
21	2	962279	SCREW, SOCKET CAP, .31X1.0, SS
22	2	920012	NUT, NYLOCK, 5/16-18, ZINC
23	1	911682	SWITCH, SNAP, BENT LEVER
24	4	980682	WASHER, FLAT, #4, ZINC
25	2	W385D	NUT, NYLOCK, #4-40, ZINC
26	2	962273	SCREW, PAN, #4-40 X .88, ZINC
27	2	873804	GROMMET .50ID .81HOLE .25THK
28	1	858304	SPRING, EXTENSION

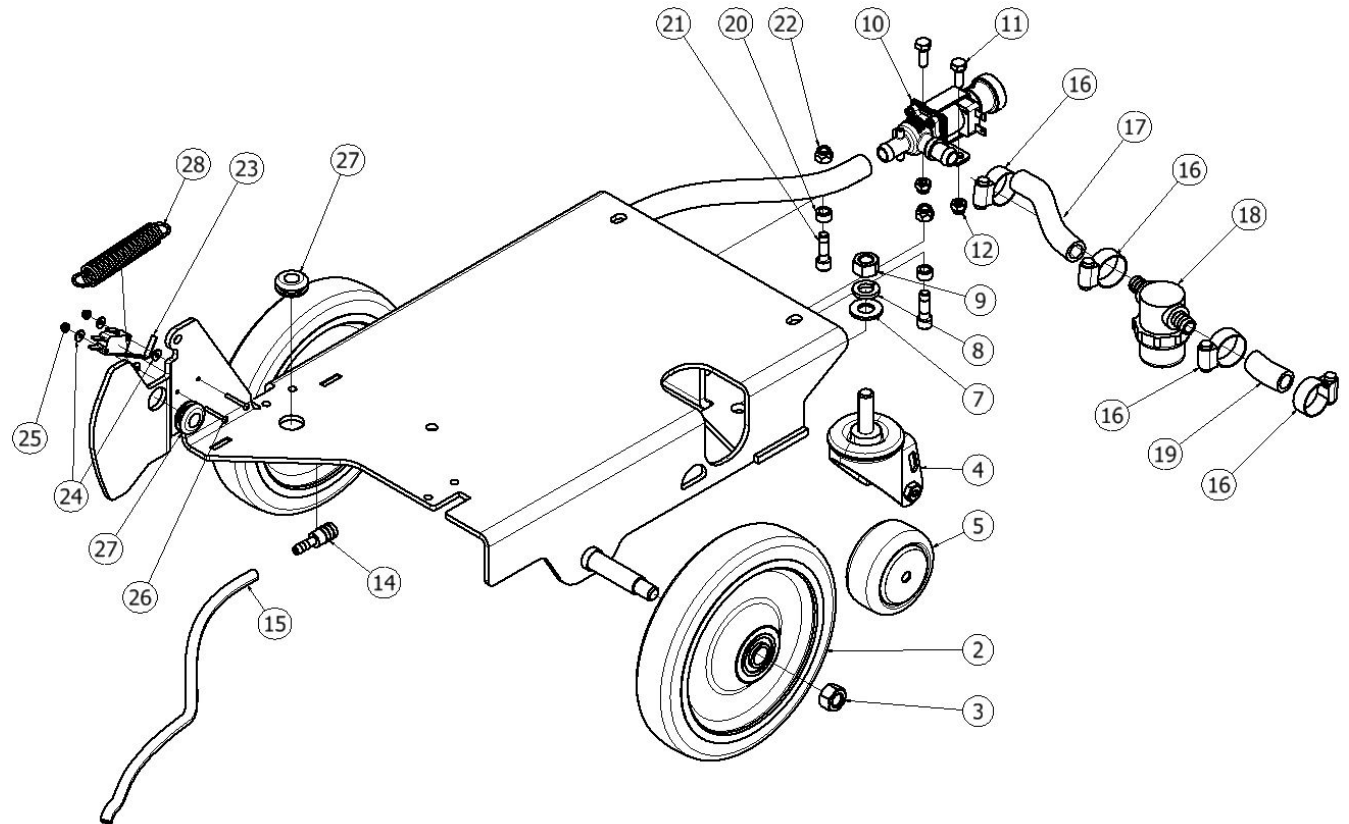

HEAD LIFT DISK & PAD ASSIST MODELS

ITEM	QTY	PART NUMBER	DESCRIPTION
1	1	850802	BRACKET, LIFT, HEAD
2	3	962279	SCREW, SOCKET CAP, .31X1.0, SS
3	2	W243D	WASHER, FLAT, 5/16, SS
4	2	853802	GUIDE, SPACER, ROUND
5	4	980612	WASHER, NYL, .50 X 1.25 X .062
6	2	920012	NUT, NYLOCK, 5/16-18, ZINC
7*	4	962442	SCREW HH .25-20 X 1.75 SS
8*	4	980002	WASHER, LOCK, SPLIT, .25
9*	4	W104D	WASHER, FLAT, .25
10*	4	855601	MOUNT, BEARING, PLASTIC
11*	2	850820	BRACKET BEARING MOUNT
12	3	980094	WASHER, SPLIT LOCK, .31, SS
13	2	962265	SCREW, BUTTON, SOCKET, .31-18 X .75, SS
14	1	858303	SPRING, EXTENSION
15	1	855103	LABEL, GRIP, FOOT
16	1	855004	KNOB, OVAL, .31-18
17	1	853801	GUIDE, LEVER
18	1	980093	WASHER, WAVE, .50INCH
19	1	855105	LEVER, DOWNPRESSURE, DUAL
20	1	980107	WASHER, FLAT, .31ID, 1.0OD, .12THK, SS
21	1	980783	WASHER WAVE .75ID

*ITEMS 7-11 CAN BE ORDERED AS A KIT UNDER PART NUMBER 855034 - KIT MOUNT HEAD LIFT REPLACEMENT.

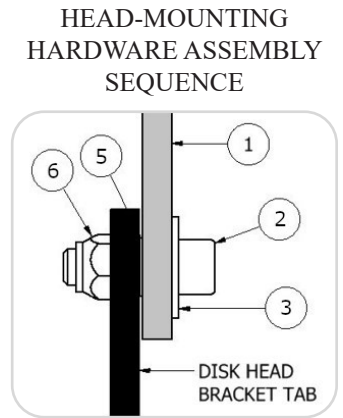
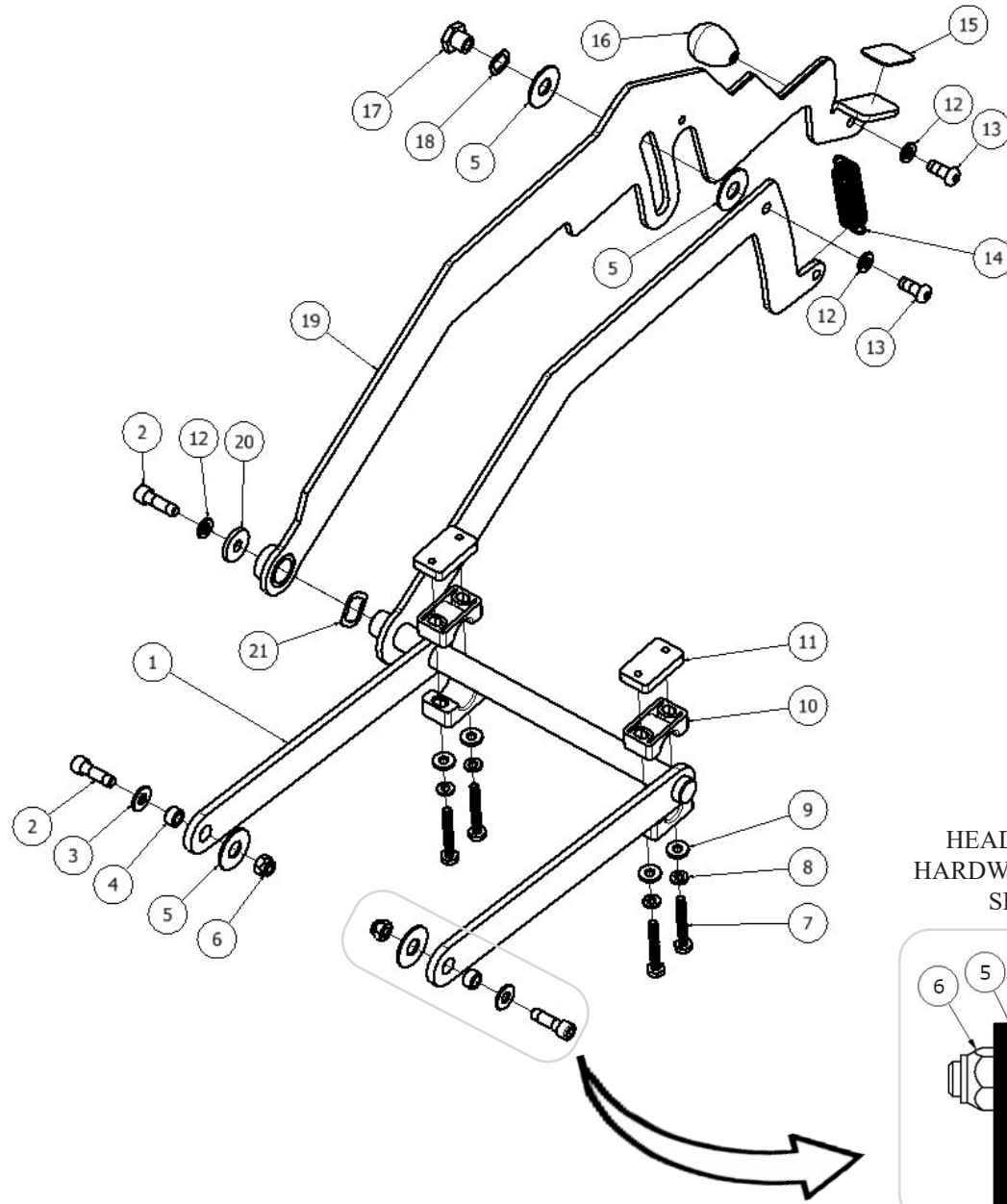

RETURN TO
TABLE OF
CONTENTS

HEAD LIFT ORBITAL MODELS

ITEM	QTY	PART NUMBER	DESCRIPTION
1	1	850802	BRACKET, LIFT, HEAD
2	2	853801	GUIDE, LEVER
3	5	980093	WASHER, WAVE, .50INCH
4	7	980612	WASHER, NYL, .50 X 1.25 X .062
5	5	980094	WASHER, SPLIT LOCK, .31, SS
6	3	962279	SCREW, SOCKET CAP, .31X1.0, SS
7*	4	962442	SCREW HH .25-20 X 1.75 SS
8*	4	980002	WASHER, LOCK, SPLIT, .25
9*	4	W104D	WASHER, FLAT, .25
10*	4	855601	MOUNT, BEARING, PLASTIC
11*	2	850820	BRACKET BEARING MOUNT
12	2	962265	SCREW, BUTTON, SOCKET, .31-18 X .75, SS
13	1	858303	SPRING, EXTENSION
14	1	855103	LABEL, GRIP, FOOT
15	1	855004	KNOB, OVAL, .31-18
16	1	853805	GUIDE, LEVER, WITH GROOVE
17	1	855801	O-RING, .44X.56X.062
18	1	855105	LEVER, DOWNPRESSURE, DUAL
19	1	980107	WASHER, FLAT, .31ID, 1.0OD, .12THK, SS
20	1	980783	WASHER WAVE .75ID
21	1	851304	BLOCK, WEIGHT, BALANCE

*ITEMS 7-11 CAN BE ORDERED AS A KIT UNDER PART NUMBER 855034 - KIT MOUNT HEAD LIFT REPLACEMENT.

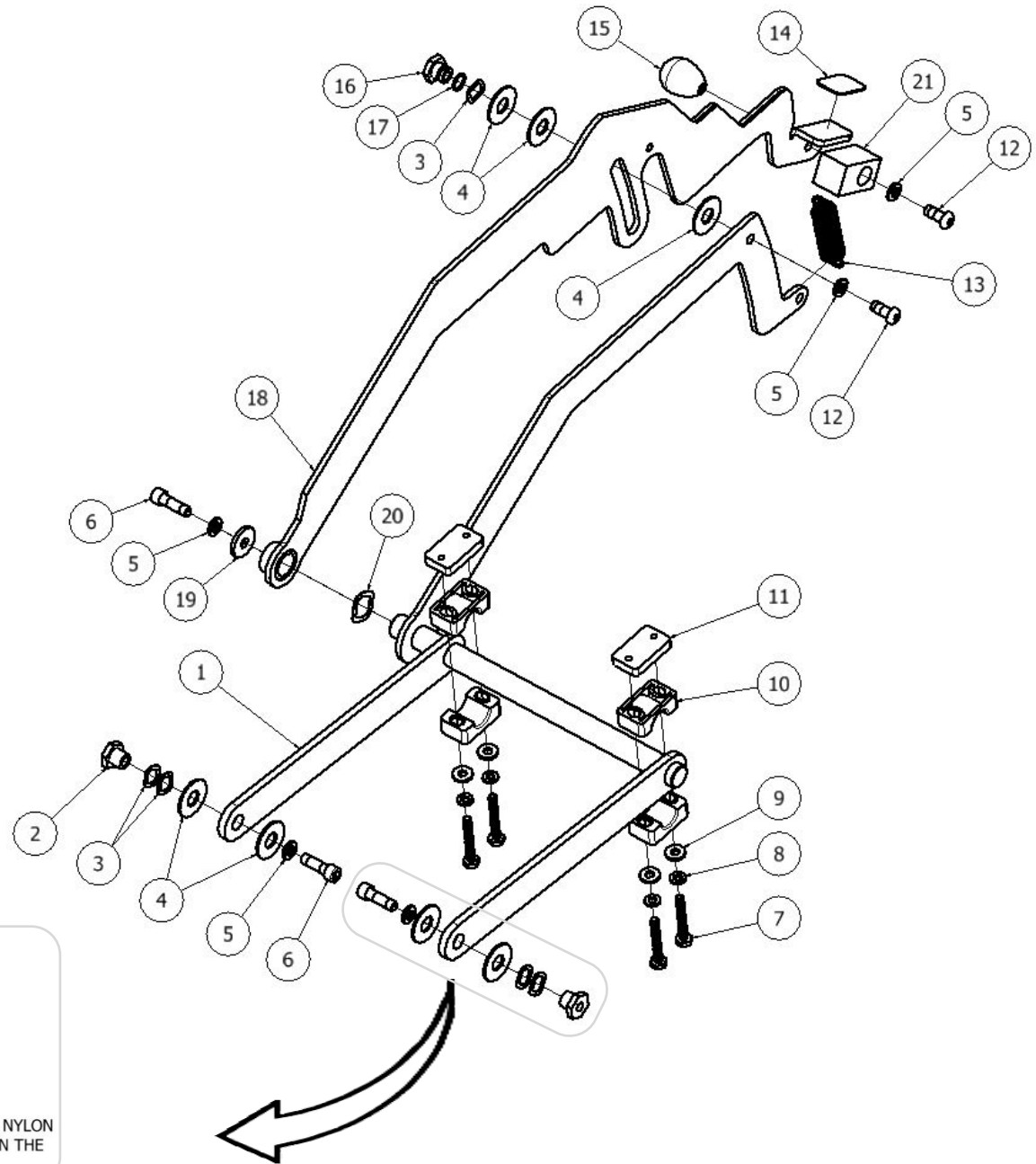

HEAD-MOUNTING HARDWARE ASSEMBLY SEQUENCE

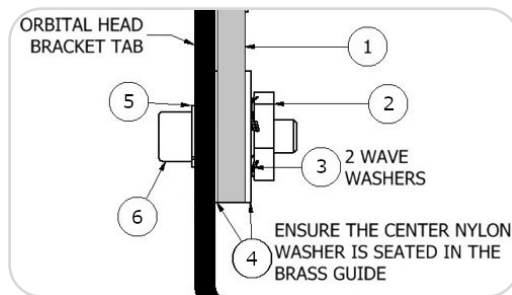

RETURN TO
TABLE OF
CONTENTS

HEAD LIFT S-24XM

ITEM	QTY	PART NUMBER	DESCRIPTION
1	1	850802	BRACKET, LIFT, HEAD
2	2	853801	GUIDE, LEVER
3	1	980093	WASHER, WAVE, .50INCH
4	7	980612	WASHER, NYL, .50 X 1.25 X .062
5	5	980094	WASHER, SPLIT LOCK, .31, SS
6	3	962279	SCREW, SOCKET CAP, .31X1.0, SS
7*	4	962442	SCREW HH .25-.20 X 1.75 SS
8*	4	980002	WASHER, LOCK, SPLIT, .25
9*	4	W104D	WASHER, FLAT, .25
10*	4	855601	MOUNT, BEARING, PLASTIC
11*	2	850820	BRACKET BEARING MOUNT
12	2	962265	SCREW, BUTTON, SOCKET, .31-18 X .75, SS
13	1	858303	SPRING, EXTENSION
14	1	855103	LABEL, GRIP, FOOT
15	1	855004	KNOB, OVAL, .31-18
16	1	853805	GUIDE, LEVER, WITH GROOVE
17	1	855801	O-RING, .44X.56X.062
18	1	855105	LEVER, DOWNPRESSURE, DUAL
19	1	980107	WASHER, FLAT, .31ID, 1.0OD, .12THK, SS
20	1	980783	WASHER WAVE .75ID

*ITEMS 7-11 CAN BE ORDERED AS A KIT UNDER PART NUMBER 855034 - KIT MOUNT HEAD LIFT REPLACEMENT.

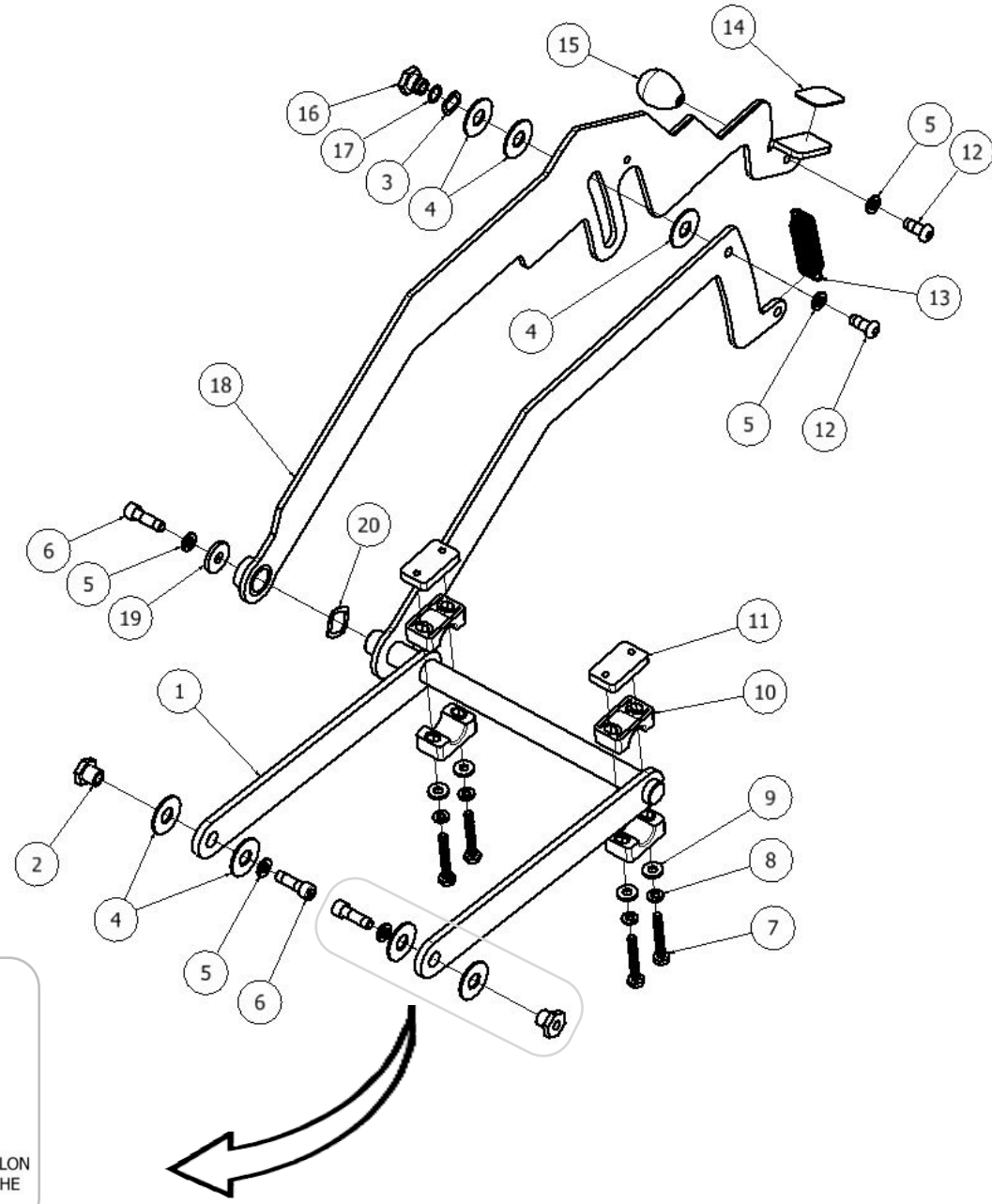

HEAD-MOUNTING HARDWARE ASSEMBLY SEQUENCE

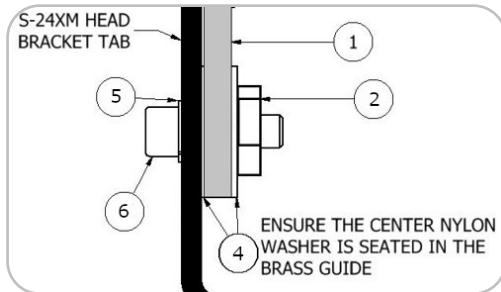

SOLUTION TANK

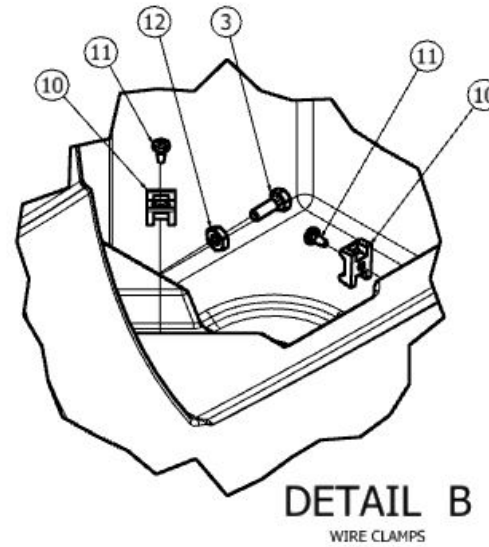
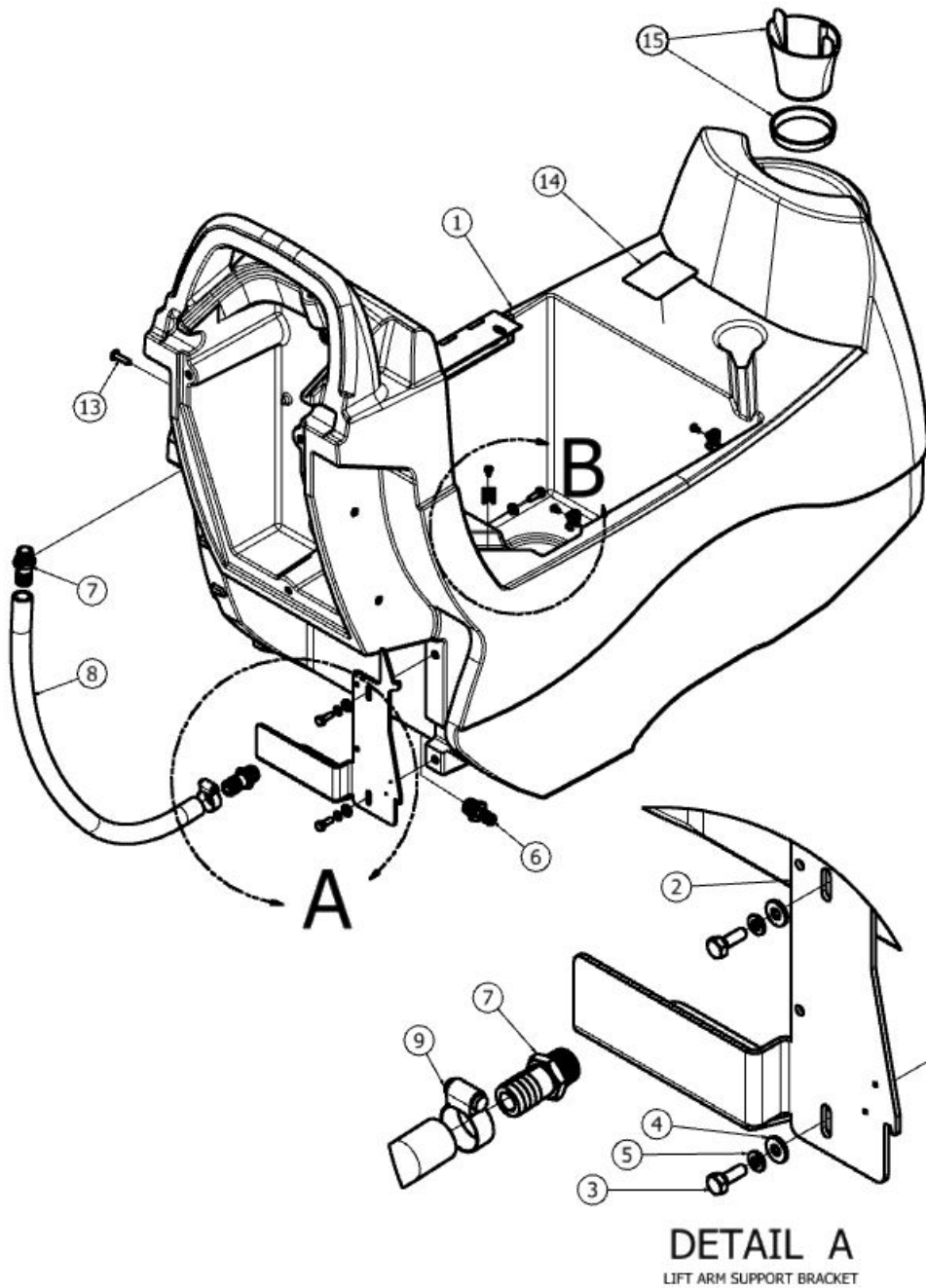

ITEM	QTY	PART NUMBER	DESCRIPTION
1	1	858601	TANK, SOLUTION, 11 GAL
2	1	850814	BRACKET, SUPPORT, LEVER
3	3	W189D	SCREW, HEX, 1/4-20 X .75, SS, PATCH
4	2	W104D	WASHER, FLAT, .25
5	2	980002	WASHER, LOCK, SPLIT, .25
6	1	223343	FITTING, STR, BM08, PM08
7	2	853303	FITTING, STR, BM12, PM08
8	1	859003	TUBE, SIGHT, REPLACEMENT
9	1	S453P	CLAMP, HOSE, WORM
10	4	225670	PAD, WIRE TIE
11	4	962271	SCREW, PAN, #10 X .38L, ZINC, SELF-TAPPING
12	1	920037	NUT, THIN JAM, 1/4-20, ZINC
13	1	962455	SCREW, TRUSS, .25-20 X 1.0
14	1	855108	LABEL, INSTRUCTION, BATTERY
15	1	875011	KIT, STRAINER, PORT, FILL

RETURN TO
TABLE OF
CONTENTS

ELECTRONICS

ITEM	QTY	PART NUMBER	DESCRIPTION
1	1	859801	PANEL, ELECTRONICS
2	1	859101	CONTROLLER, TRACTION, S20
3	4	980025	WASHER, SPLIT LOCK, #6, ZINC
4	2	W323D	SCREW, PAN, #6-32 X 1.0, ZINC
5	2	912402	CONTACTOR, 24VDC, 70A
6	1	912401	CONTACTOR, 24V, 100A
7	4	962363	SCREW, PAN, #10-32 X .50, SS
8	2	W401D	WASHER, FLAT, #10
9	4	980022	WASHER, LOCK, SPLIT, #10
10	2	858501	STAND-OFF, INSULATED, .25-20
11	4	W169D	SCREW, HEX, .25-20 X .50
12	6	W104D	WASHER, FLAT, .25
13	6	980002	WASHER, LOCK, SPLIT, .25
14	2	962276	SCREW, SET, .25-20 X 1.25, ZINC, PATCH
15	2	980033	WASHER, FLAT, #6, SS
16	2	W315D	SCREW, PAN, #6-32 X .50, BLK
17	1	911685	RELAY, 24VDC, BATTERYSHIELD
18	2	924083	NUT .25-20 FLEX LOCK ZINC

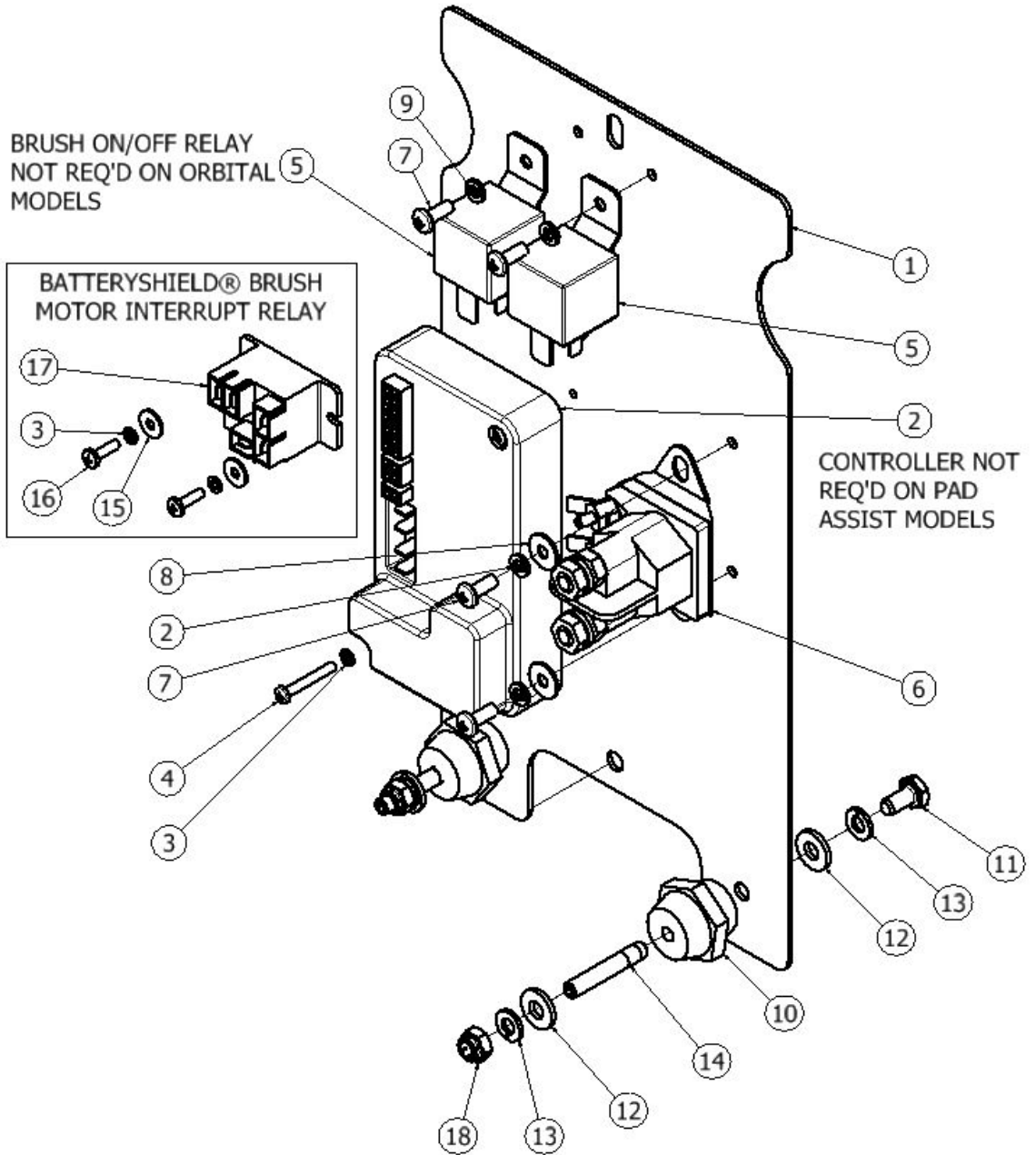

BATTERY

ITEM	QTY	PART NUMBER	DESCRIPTION
1	2	851303	BATTERY, 12V, 155AH, LEAD ACID
1	2	841311	BATTERY, 12V, 140AH, AGM
1	2	881350	BATTERY, 12V, 130AH, LEAD ACID
1	2	851302	BATTERY, 12V, 105AH, AGM
1	2	851311	BATTERY 12V 115AH LA
2	1	858202	FOAM, SPACER, BATTERY
3	1	911640	HARNESS, CONN, BATTERY
4	1	911641	HARNESS, CONN, BATTERY
5	1	878520	SENSOR ASSY BATTERYSHIELD FIELD REPLACE
6	1	879002	TUBE & PUMP ASSY (NOT SHOWN, OPTIONAL)
7	1	857003	PUMP ASSY HAND HYDROLINK (OPTIONAL)
8	1	855605	MANIFOLD INDIV HYDROLINK (BATT CAP)

BATTERYSHIELD® SENSOR IS MATED AND CALIBRATED TO THE MANIFOLD (BATT CAP) FROM THE FACTORY. SENSOR AND CAP MUST BE REPLACED AS AN ASSEMBLY – **DO NOT REMOVE SENSOR FROM CAP**

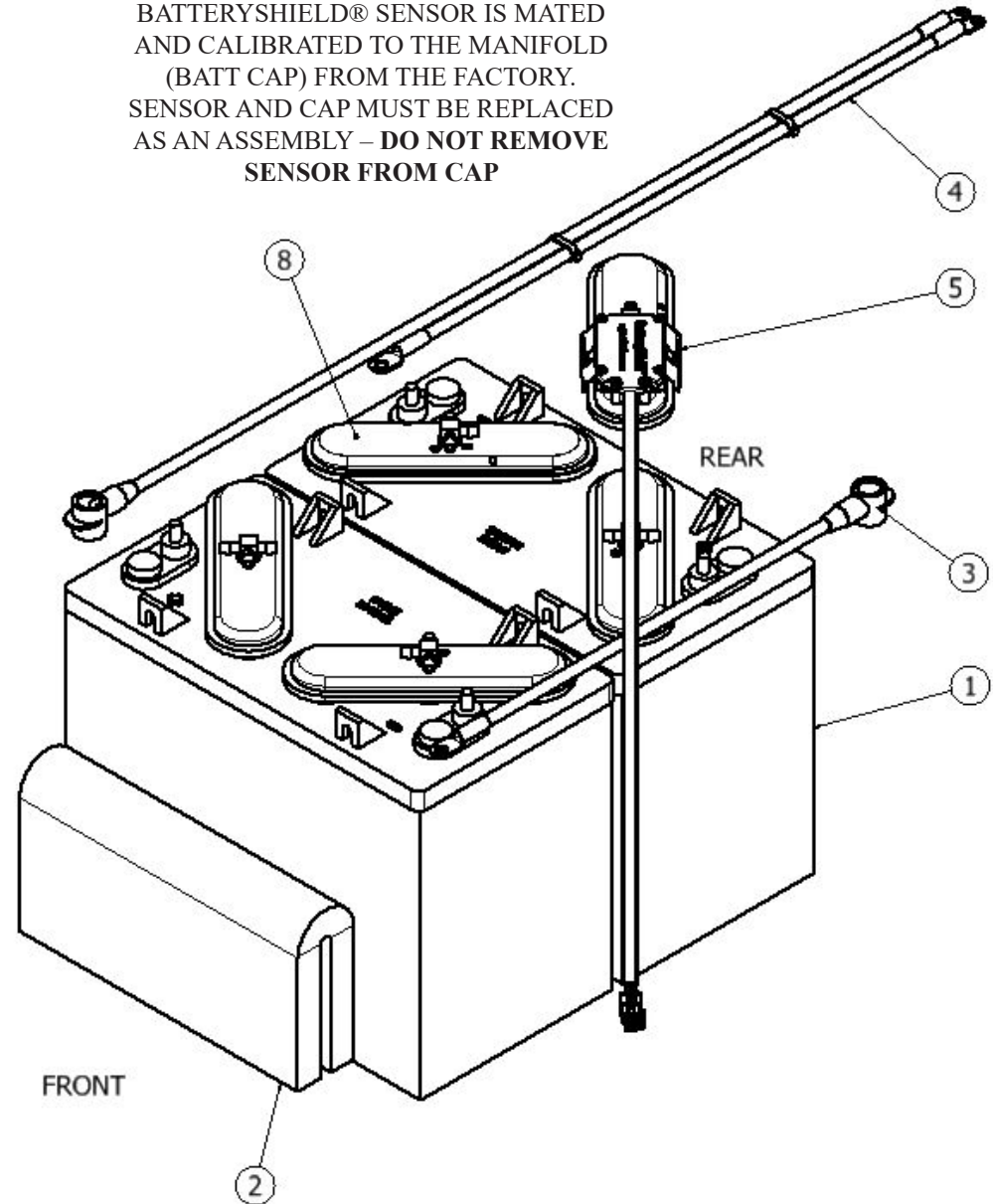
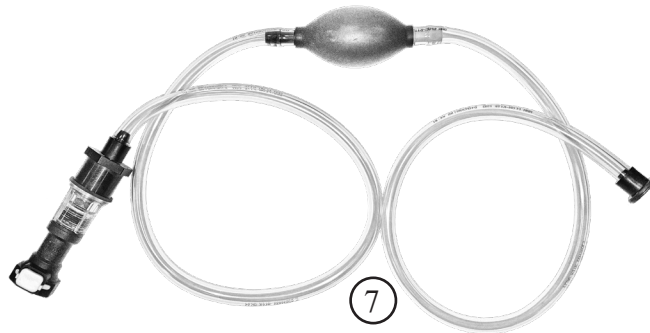

RETURN TO
TABLE OF
CONTENTS

CONTROLS

S-24XM & TRACTION MODELS

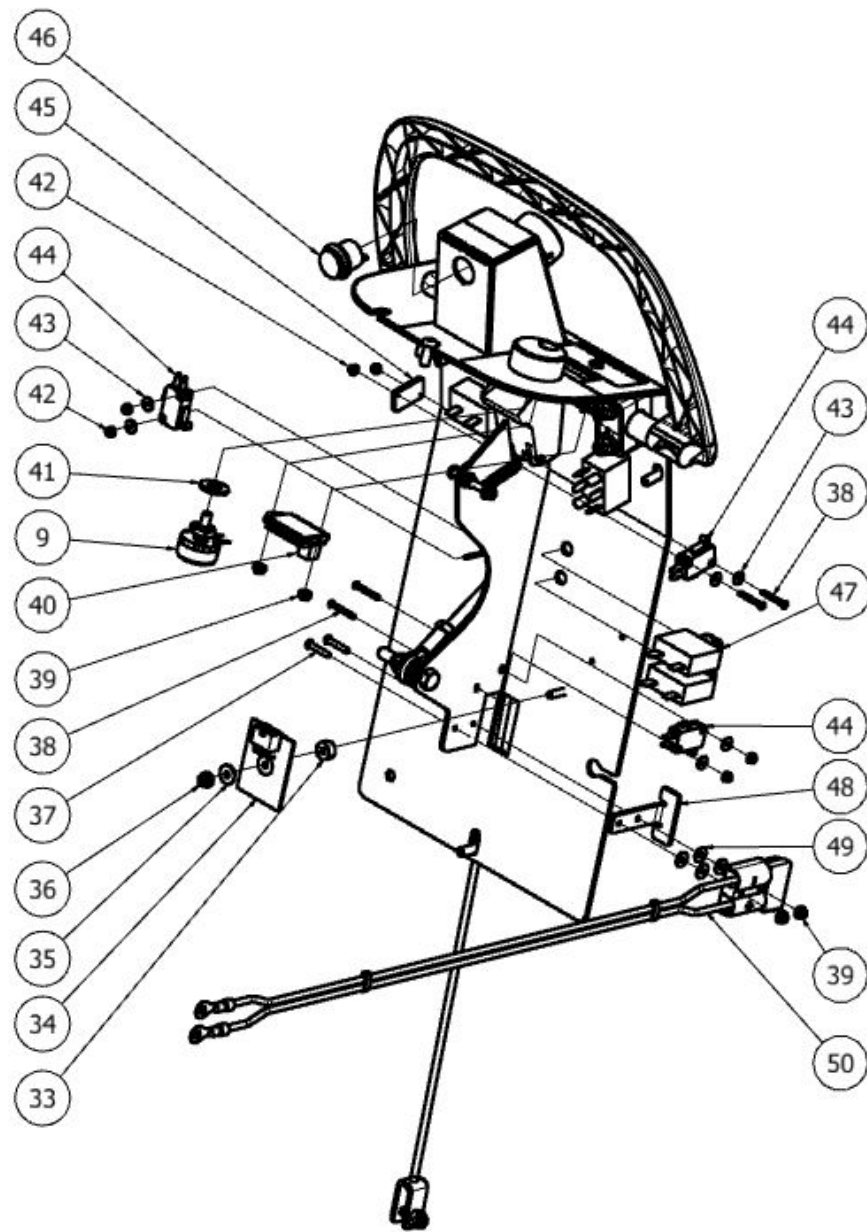
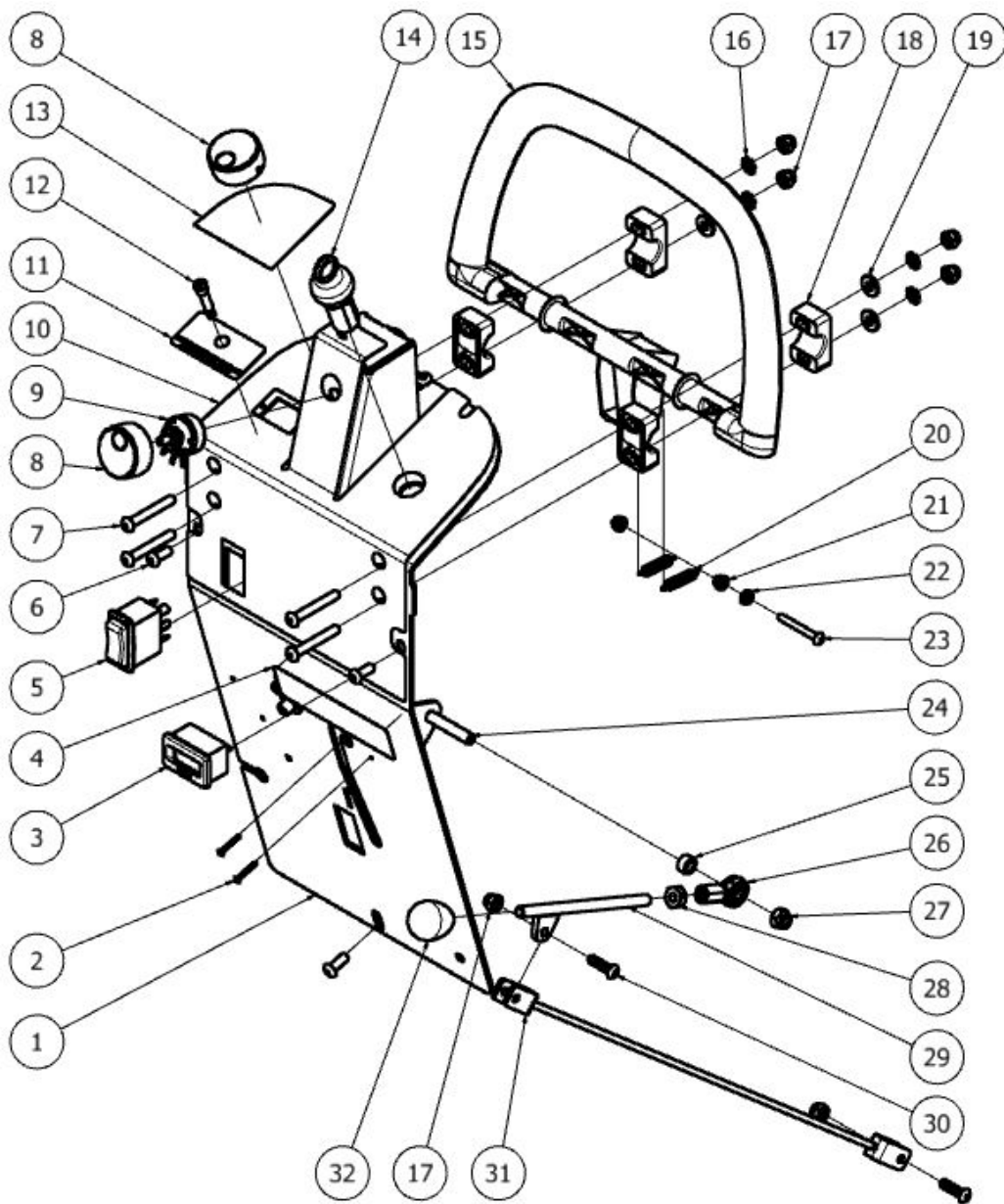

CONTROLS S-24XM & TRACTION MODELS

ITEM	QTY	PART NUMBER	DESCRIPTION
1	1	857101	PANEL, CONTROLS
2	2	962209	SCREW PHPS 4-40 X .75 SS BL
3	1	911661	METER, HOUR, DIGITAL (OPTIONAL)
4	1	855111	LABEL, QR CODE, S-20
5	1	911649	SWITCH, ROCKER, AUTO ON-OFF
6	4	962263	SCREW BHCS .25-20 X .63 SS BL
7	4	962264	SCREW BHCS .25-20 X 1.75 SS BL
8	2	855001	KNOB, ADJUST, .25 BORE
9	2	911664	POTENTIOMETER ASSY, 5K
10	1	855117	LABEL CONTROL 11GAL DISK
10	1	855118	LABEL CONTROL 11GAL ORB
11	1	855115	LABEL BATTERYSHIELD WITH QR CODE
12	1	875107	LED, RED, 24VDC
13	1	855119	LABEL COVER SOLUTION S-20
14	1	911647	SWITCH KEY
15	1	851301	BAIL, MOLDED
16	4	980029	WASHER, LOCK, .25, STAR, EXT
17	6	920011	NUT HEX .25-20 NYLOCK ZINC
18	4	855601	MOUNT BEARING PLASTIC
19	4	W104D	WASHER, FLAT, .25
20	2	858302	SPRING, EXTENSION
21	2	920666	NUT HEX 10-32 NYLOCK SS
22	1	920013	NUT HEX 10-32 ZINC
23	1	962146	SCREW PHPS 10-32 X 1.5 ZINC
24	1	962270	SCREW HH .31-18 X 1.75 SS
25	1	853802	GUIDE, SPACER, ROUND
26	1	902050	BEARING, ROD END, .31-24
27	1	920012	NUT HEX .31-18 NYLOCK ZINC
28	1	920038	NUT HEX .31-24 SS
29	1	855106	LEVER, LIFT, SQUEEGEE
30	2	962210	SCREW BHCS .25-20 X .875 SS

ITEM	QTY	PART NUMBER	DESCRIPTION
31	1	852401	CABLE, LIFT, CLEVIS
32	1	855004	KNOB OVAL .31-18
33	3	878208	SPACER PLASTIC #10 X .25 THICK
34	1	872413	CONTROLLER FLOW WATER
35	1	W401D	WASHER, FLAT, #10
36	1	920001	NUT HEX 10-32 NYLOCK ZINC
37	6	W132D	SCREW PHPS 6-32 X .75 SS
38	4	962273	SCREW PHPS 4-40 X .88 ZINC
39	4	920034	NUT HEX 6-32 NYLOCK SS
40	1	911621	METER, BATTERY
41	1	980003	WASHER, FLAT, .38
42	6	W385D	NUT HEX 4-40 NYLOCK ZINC
43	6	980682	WASHER, FLAT, #4, ZINC
44	3	911646	SWITCH, SNAP, WITH ROLLER
45	1	856608	PLATE, MOUNTING
46	1	911653	SWITCH, ROUND, ON - MOM
47	2	911622	CIRCUIT BREAKER, 30 AMPS
48	1	850806	BRACKET, PLUG
49	8	980033	WASHER, FLAT, #6, SS
50	1	911645	HARNESS, CHARGER, POST
51	1	911643	HARNESS, MAIN, TRACTION
52	1	911667	HARNESS, SIGNAL, S20T, DK
53	1	911668	HARNESS, SIGNAL, S20T, OR
54	1	911670	HARNESS, PWR, S-20 ORBIT
55	1	911688	HARNESS, POWER, S-24XM
56	1	911722	HARNESS SOLUTION FLOW S-SERIES

CONTROLS S-20HD

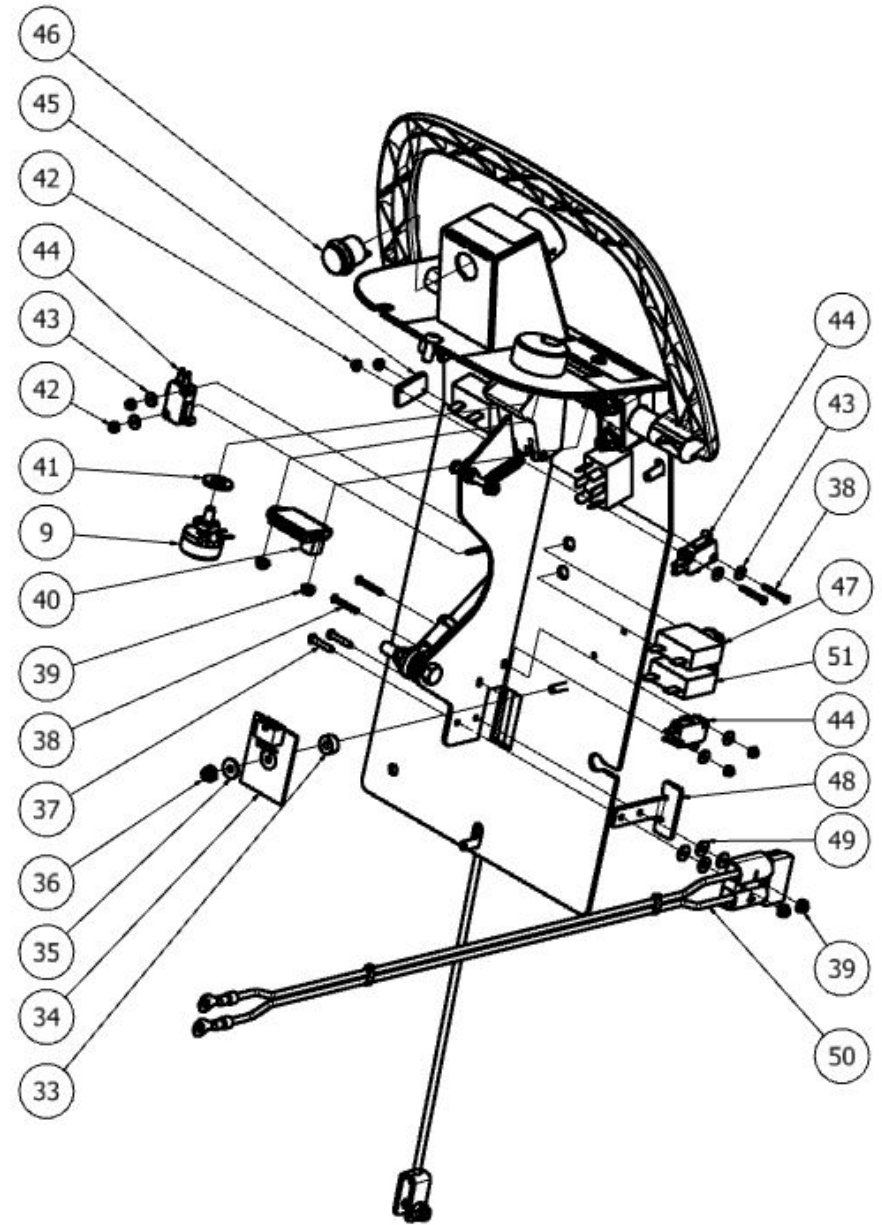
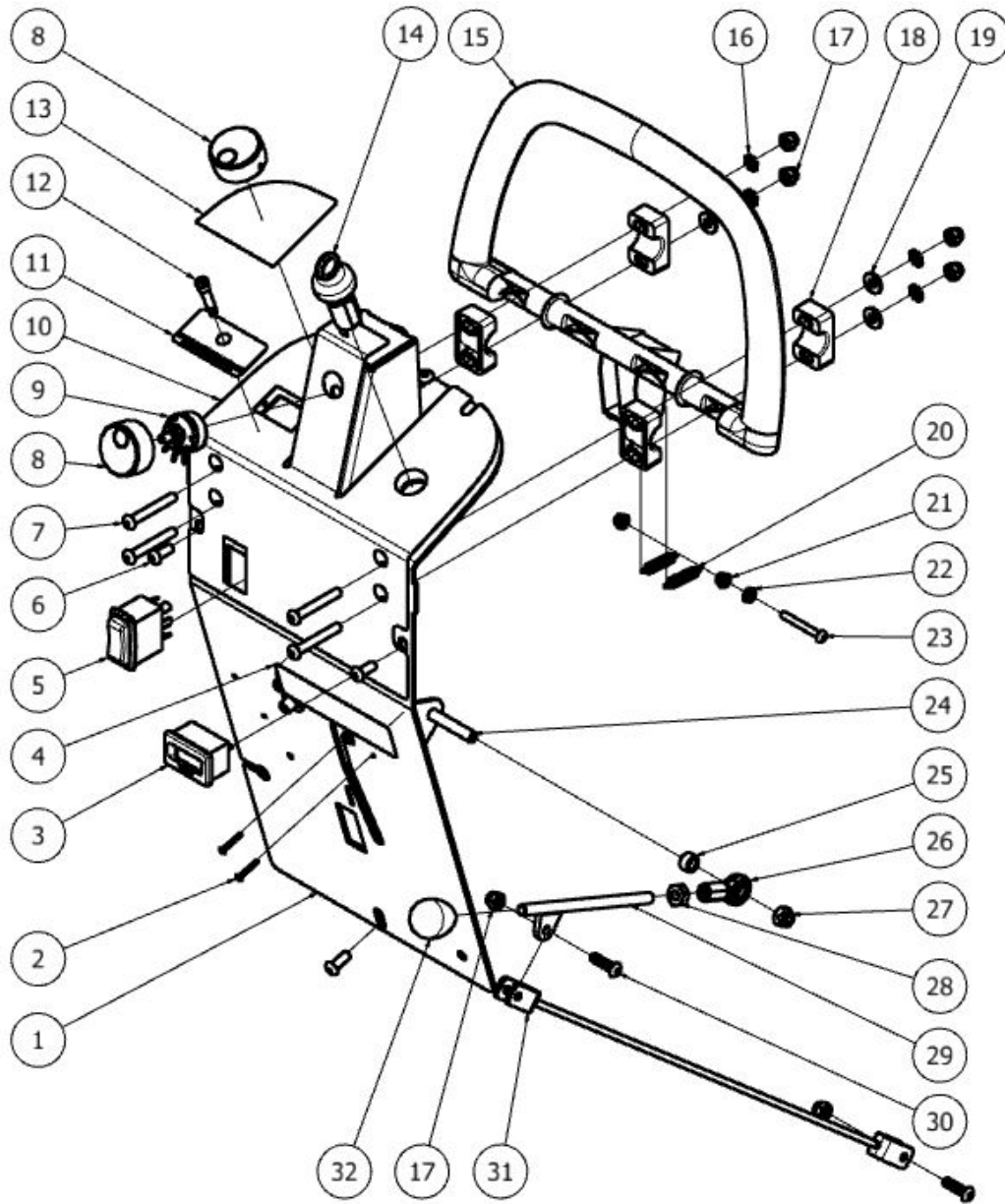

CONTROLS S-20HD

ITEM	QTY	PART NUMBER	DESCRIPTION
1	1	857101	PANEL, CONTROLS
2	2	962209	SCREW PHPS 4-40 X .75 SS BL
3	1	911661	METER, HOUR, DIGITAL (OPTIONAL)
4	1	855111	LABEL, QR CODE, S-20
5	1	911649	SWITCH, ROCKER, AUTO ON-OFF
6	4	962263	SCREW BHCS .25-20 X .63 SS BL
7	4	962264	SCREW BHCS .25-20 X 1.75 SS BL
8	2	855001	KNOB, ADJUST, .25 BORE
9	2	911664	POTENTIOMETER ASSY, 5K
10	1	855117	LABEL CONTROL 11GAL DISK
10	1	855118	LABEL CONTROL 11GAL ORB
11	1	855115	LABEL BATTERYSHIELD WITH QR CODE
12	1	875107	LED, RED, 24VDC
13	1	855119	LABEL COVER SOLUTION S-20
14	1	911647	SWITCH KEY
15	1	851301	BAIL, MOLDED
16	4	980029	WASHER, LOCK, .25, STAR, EXT
17	6	920011	NUT HEX .25-20 NYLOCK ZINC
18	4	855601	MOUNT BEARING PLASTIC
19	4	W104D	WASHER, FLAT, .25
20	2	858302	SPRING, EXTENSION
21	2	920666	NUT HEX 10-32 NYLOCK SS
22	1	920013	NUT HEX 10-32 ZINC
23	1	962146	SCREW PHPS 10-32 X 1.5 ZINC
24	1	962270	SCREW HH .31-18 X 1.75 SS
25	1	853802	GUIDE, SPACER, ROUND
26	1	902050	BEARING, ROD END, .31-24
27	1	920012	NUT HEX .31-18 NYLOCK ZINC
28	1	920038	NUT HEX .31-24 SS
29	1	855106	LEVER, LIFT, SQUEEGEE
30	2	962210	SCREW BHCS .25-20 X .875 SS

ITEM	QTY	PART NUMBER	DESCRIPTION
31	1	852401	CABLE, LIFT, CLEVIS
32	1	855004	KNOB OVAL .31-18
33	3	878208	SPACER PLASTIC #10 X .25 THICK
34	1	872413	CONTROLLER FLOW WATER
35	1	W401D	WASHER, FLAT, #10
36	1	920001	NUT HEX 10-32 NYLOCK ZINC
37	6	W132D	SCREW PHPS 6-32 X .75 SS
38	4	962273	SCREW PHPS 4-40 X .88 ZINC
39	4	920034	NUT HEX 6-32 NYLOCK SS
40	1	911621	METER, BATTERY
41	1	980003	WASHER, FLAT, .38
42	6	W385D	NUT HEX 4-40 NYLOCK ZINC
43	6	980682	WASHER, FLAT, #4, ZINC
44	3	911646	SWITCH, SNAP, WITH ROLLER
45	1	856608	PLATE, MOUNTING
46	1	911653	SWITCH, ROUND, ON - MOM
47	2	911622	CIRCUIT BREAKER, 30 AMPS
48	1	850806	BRACKET, PLUG
49	8	980033	WASHER, FLAT, #6, SS
50	1	911645	HARNESS, CHARGER, POST
51	1	911681	CIRCUIT BREAK 35 AMPS
52	1	911643	HARNESS, MAIN, TRACTION
53	1	911667	HARNESS, SIGNAL, S20T, DK
54	1	911668	HARNESS, SIGNAL, S20T, OR
55	1	911670	HARNESS, PWR, S-20 ORBIT
56	1	911688	HARNESS, POWER, S-24XM
57	1	911722	HARNESS SOLUTION FLOW S-SERIES

CONTROLS PAD ASSIST MODELS

ITEM	QTY	PART NUMBER	DESCRIPTION
1	1	857001	PANEL, CONTROLS
2	1	855101	LABEL, CONTROL, BA
3	1	911647	SWITCH KEY
4	4	962264	SCREW BHCS .25-20 X 1.75 SS BL
5	1	911649	SWITCH, ROCKER, AUTO ON-OFF
6	4	962263	SCREW BHCS .25-20 X .63 SS BL
7	2	962209	SCREW PHPS 4-40 X .75 SS BL
8	3	911646	SWITCH, SNAP, WITH ROLLER
9	6	980682	WASHER, FLAT, #4, ZINC
10	4	962273	SCREW PHPS 4-40 X .88 ZINC
11	1	911622	CIRCUIT BREAKER, 30 AMPS
12	6	W385D	NUT HEX 4-40 NYLOCK ZINC
13	1	850806	BRACKET, PLUG
14	4	980033	WASHER, FLAT, #6, SS
15	4	920034	NUT HEX 6-32 NYLOCK SS
16	1	911645	HARNES, CHARGER, POST
17	1	962270	SCREW HH .31-18 X 1.75 SS
18	2	W132D	SCREW PHPS 6-32 X .75 SS
19	1	855035	KIT METER HOUR REPLACEMENT PA
20	1	856608	PLATE, MOUNTING
21	6	920011	NUT HEX .25-20 NYLOCK ZINC
22	1	852401	CABLE, LIFT, CLEVIS
23	2	920666	NUT HEX 10-32 NYLOCK SS
24	1	920013	NUT HEX 10-32 ZINC
25	2	858302	SPRING, EXTENSION
26	1	962146	SCREW PHPS 10-32 X 1.5 ZINC
27	4	W104D	WASHER, FLAT, .25
28	4	980029	WASHER, LOCK, .25, STAR, EXT
29	4	855601	MOUNT BEARING PLASTIC
30	1	851301	BAIL, MOLDED
31	1	920012	NUT HEX .31-18 NYLOCK ZINC
32	1	902050	BEARING, ROD END, .31-24
33	1	853802	GUIDE, SPACER, ROUND
34	1	920038	NUT HEX .31-24 SS
35	2	962210	SCREW BHCS .25-20 X .875 SS
36	1	855106	LEVER, LIFT, SQUEEGEE
37	1	855004	KNOB OVAL .31-18
38	1	911644	HARNES, MAIN, BA
39	1	911669	HARNES, SIGNAL, S20BA

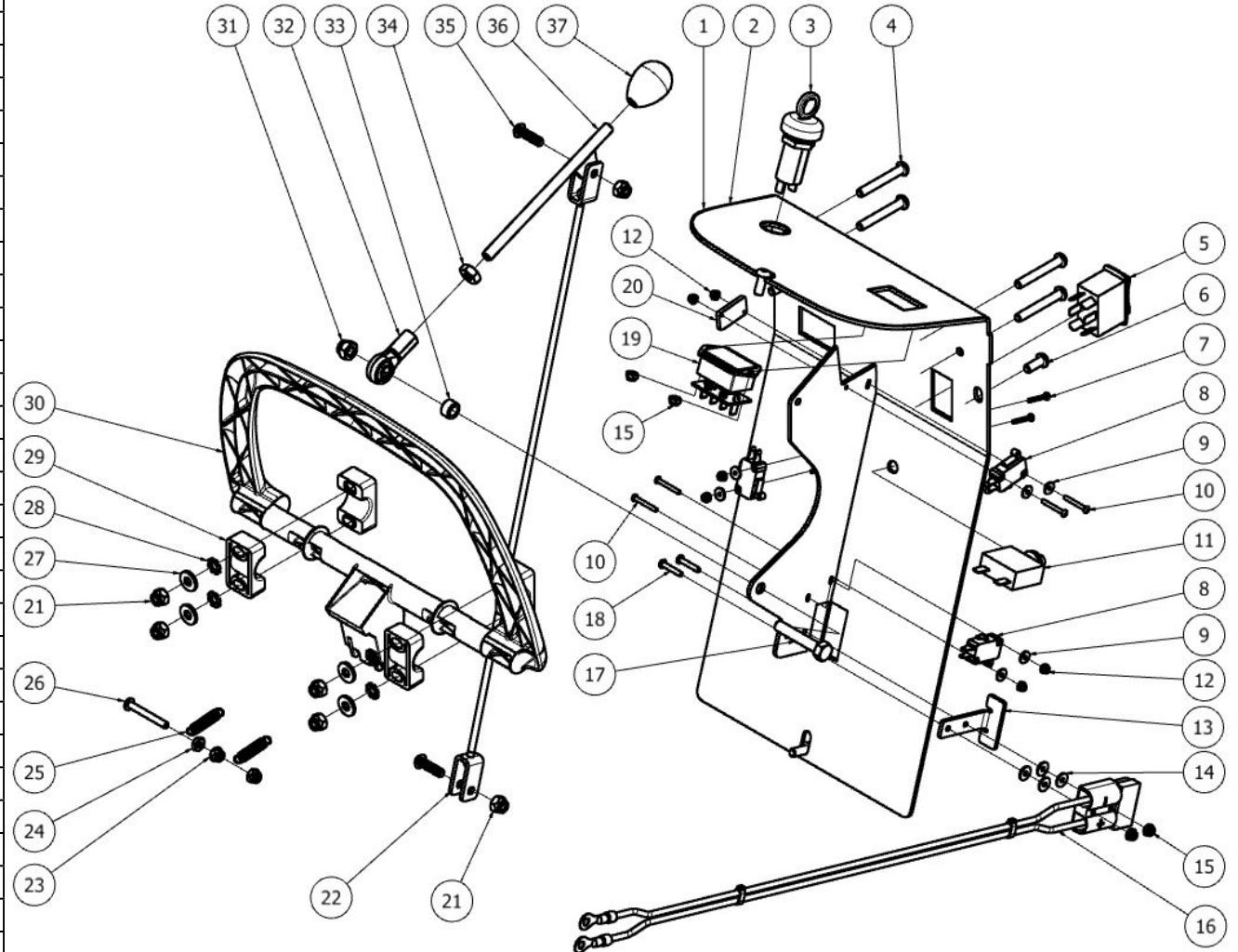

OPTIONAL SCRUBSMART TELEMETRY SYSTEM

ITEM	QTY	PART NUMBER	DESCRIPTION
1	4	W132D	SCREW PAN #6-32 X 1.0 ZINC
2	6	980025	WASHER SPLIT LOCK #6 ZINC
3	1	895002	KEYPAD TELEMETRY TRACKING
4	2	962460	SCREW, #8X.75, PHIL TRUSS SS
5	1	850818	BRACKET MTG KEYPAD
6	2	878208	SPACER PLASTIC #10 X .25 THICK
7	1	870826	BRACKET MTG RELAY
8	1	911685	RELAY, 24VDC, BATTERYSHIELD
9	4	980033	WASHER, FLAT, #6, SS
10	2	W315D	SCREW, PAN, #6-32 X .50, BLK
11	1	873805	GROMMET LOCKING 1/2" ID
12	1	899203	TRANSMITTER TELEMETRY TRACKING

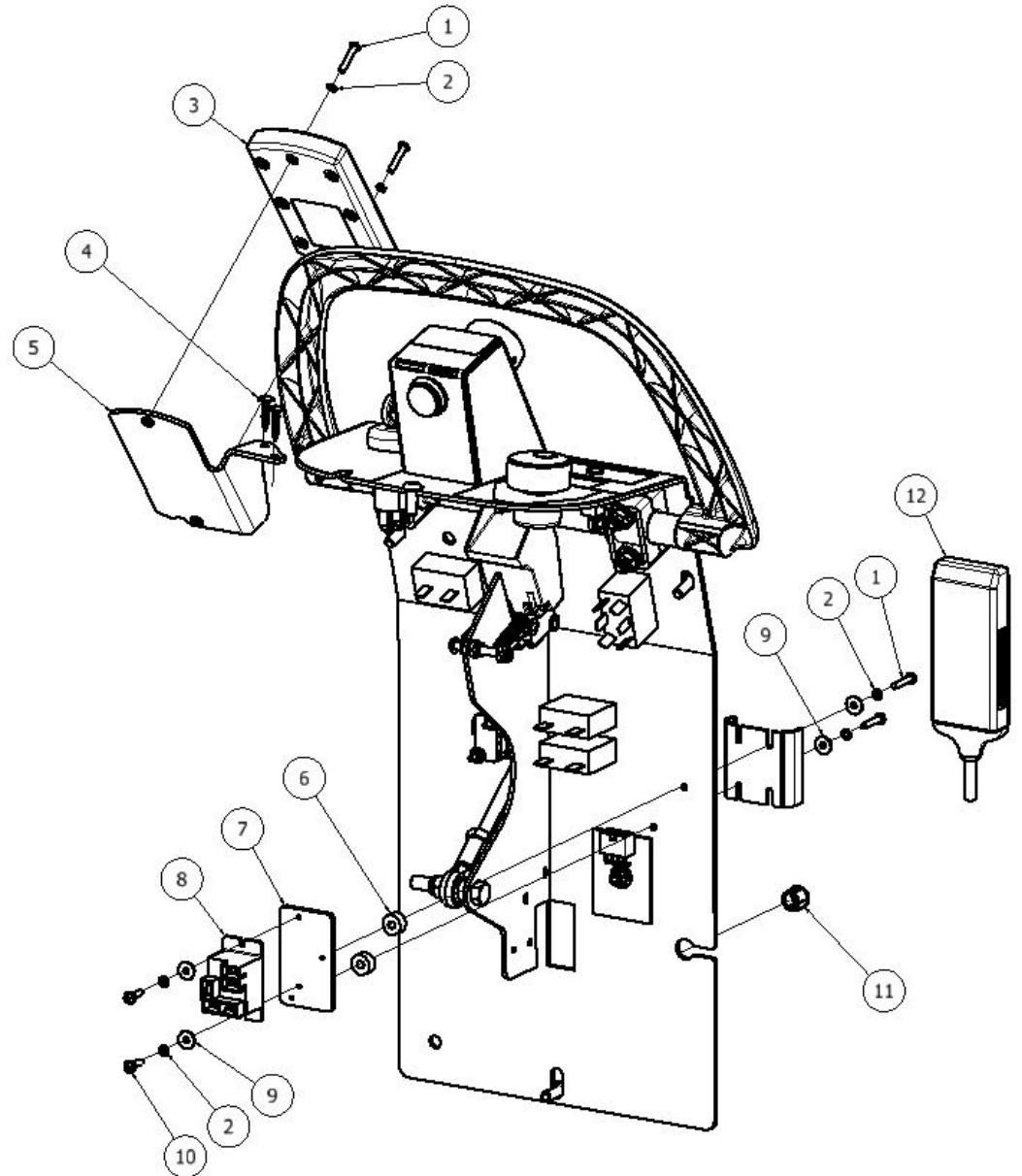

RECOVERY TANK ASSEMBLY

PRIOR TO SERIAL NUMBER 124471 – CONFIRM SERIAL NUMBER BEFORE ORDERING REPLACEMENT PARTS

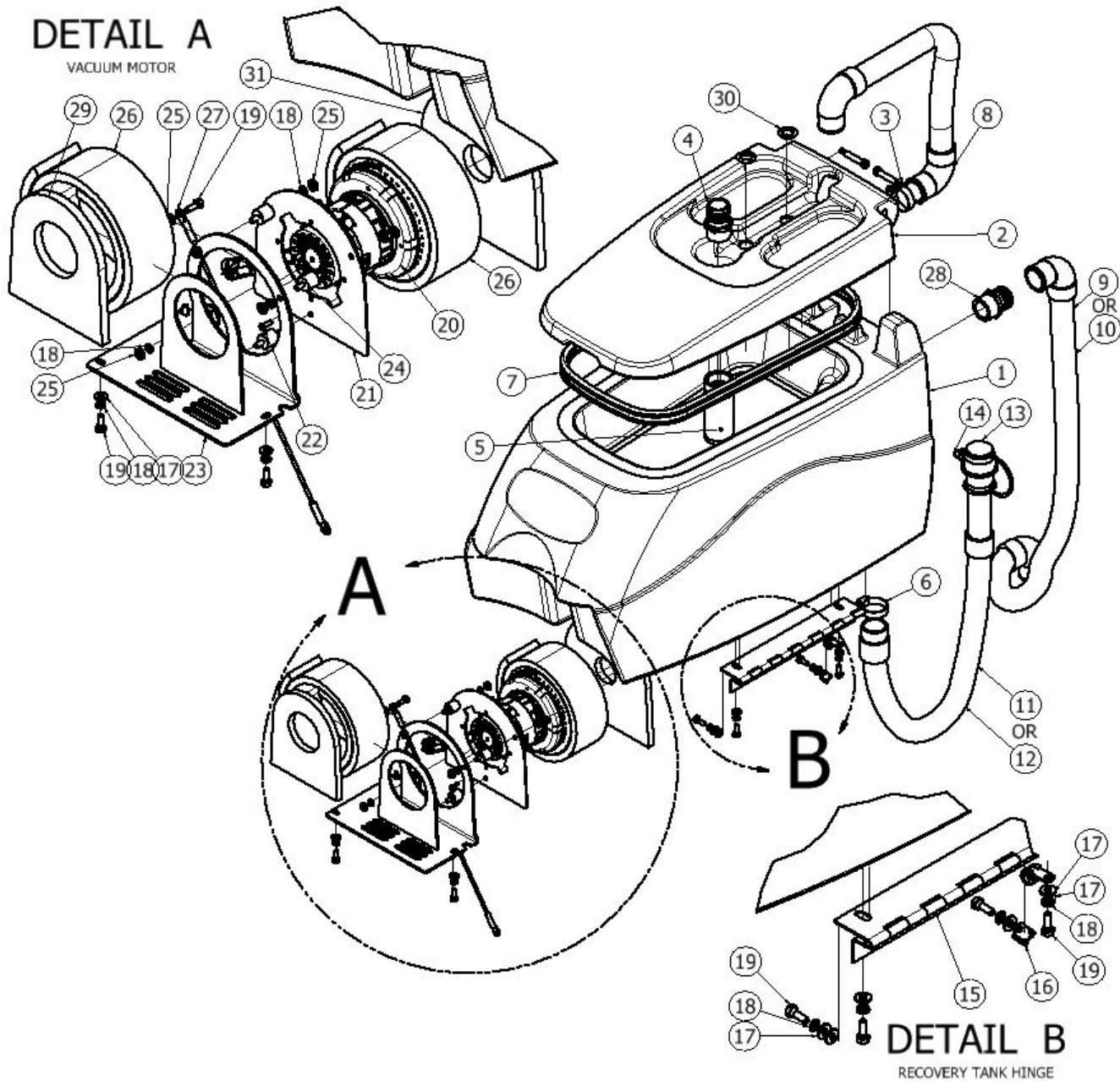

RECOVERY TANK ASSEMBLY

*****PRIOR TO SERIAL NUMBER 124471 – CONFIRM SERIAL NUMBER BEFORE ORDERING REPLACEMENT PARTS*****

ITEM	QTY	PART NUMBER	DESCRIPTION
1	1	858602	TANK, RECOVERY, 11 GA
2	1	852301	COVER, TANK, RECOVERY
3	2	962462	SCREW, SHOULDER, .38 X 1.75, SS
4	1	853304	FITTING, STR, BM24, PM20
5	1	223370	FLOAT, SHUTOFF
6	3	S611A	CLAMP, HOSE, WORM
7	1	853402	GASKET, COVER, PRESS-IN
8	1	854103	HOSE, VACUUM, 1.5INCH
9	1	854102	HOSE, SQUEEGEE, 90 CUFF
10	1	854105	HOSE SQUEEGEE S-20 CHEM RESIST
11	1	854101	HOSE, DRAIN, CAPPED
12	1	854104	HOSE DRAIN CAPPED CHEM RESIST
13	1	851501	CAP HOSE DRAIN - REPL FOR 854101
14	1	858506	STRAP SUPPORT HOSE
15	1	854501	HINGE, TANK, RECOVERY
16	2	852101	CLAMP, WIRE, P-SHAPED
17	9	W104D	WASHER, FLAT, .25
18	14	980002	WASHER, LOCK, SPLIT, .25
19	8	W189D	SCREW, HEX, 1/4-20 X .75, SS, PATCH
20	1	855205	MOTOR VAC 24VDC PERIPH
21	1	850812	BRACKET, MTG, ISOLATOR
22	4	964224	SCREW, PAN, #10 X .5, SELF TAPPING
23	1	852303	COVER, MTG, VACUUM
24	3	855603	MOUNT, RUBBER, .25-20
25	8	920037	NUT, THIN JAM, 1/4-20, ZINC
26	2	853305	FOAM, NOISE, VACUUM
27	1	852409	CABLE RETENTION TANK S-20 LONG
28	1	853308	FITTING, MODIFIED
29	1	873314	GASKET, FOAM, VACUUM
30	2	856803	PLUG HOLE 1 INCH BLACK
31	1	853310	FOAM BARRIER NOISE

AVAILABLE VACUUM MOTOR KIT - #855019

ITEM	DESCRIPTION	QTY
857802	SHEET INSTRUCTION S-20 VAC MTR REPL	1
853305	FOAM,NOISE,VACUUM	2
911104	TIE-CABLE 14.5 LG 9531 H400014 H400002	4
873314	GASKET, FOAM, VACUUM	1
853310	FOAM BARRIER NOISE	1
855205	MTR, VAC,24VDC,2STG - KIT 855019 AVAIL	1

RECOVERY TANK ASSEMBLY

AFTER SERIAL NUMBER 124471 – CONFIRM SERIAL NUMBER BEFORE ORDERING REPLACEMENT PARTS

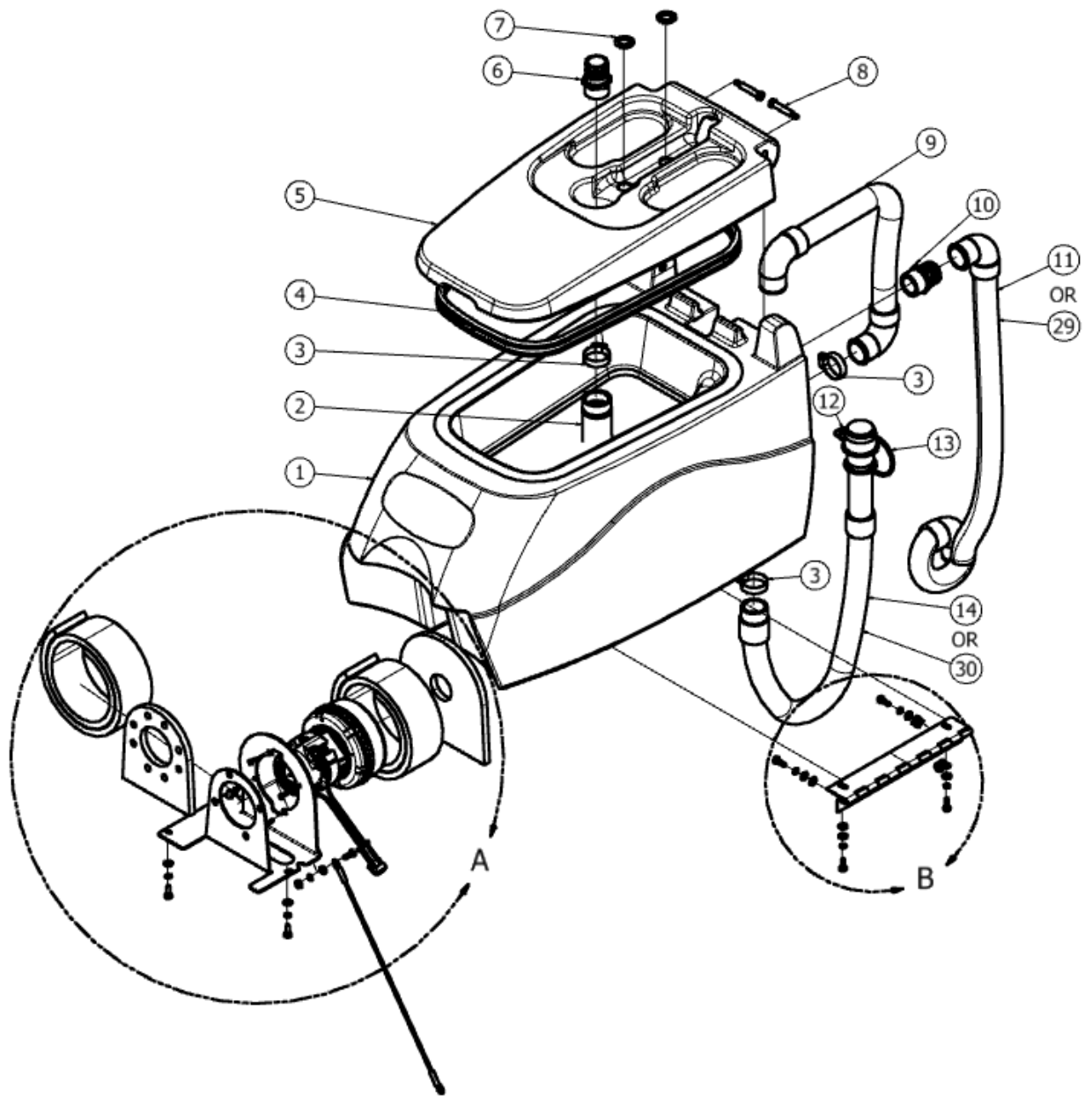
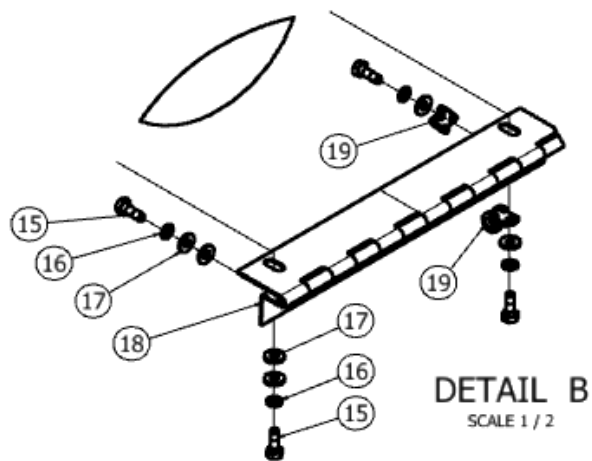
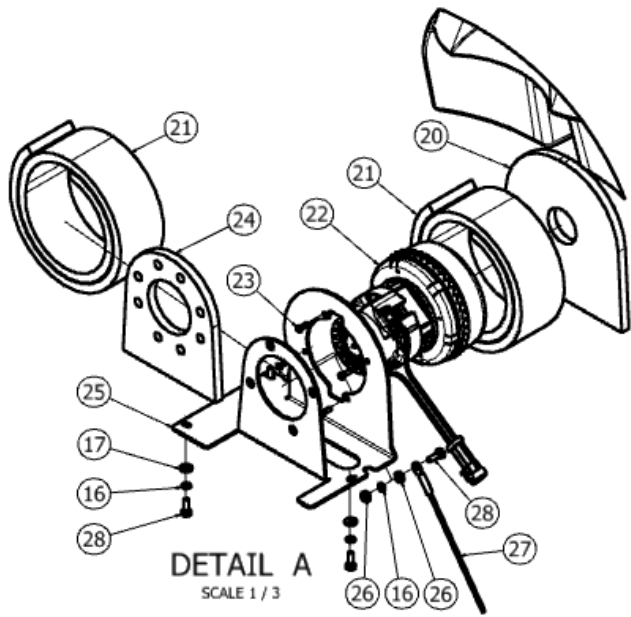

RECOVERY TANK ASSEMBLY

AFTER SERIAL NUMBER 124471 – CONFIRM SERIAL NUMBER BEFORE ORDERING REPLACEMENT PARTS

ITEM	QTY	PART NUMBER	DESCRIPTION
1	1	858602	TANK, RECOVERY, 11 GA
2	1	223370	FLOAT, SHUTOFF
3	3	S611A	CLAMP, HOSE, WORM
4	1	853402	GASKET, COVER, PRESS-IN
5	1	852301	COVER, TANK, RECOVERY
6	1	853304	FITTING, STR, BM24, PM20
7	2	856803	PLUG HOLE 1 INCH BLACK
8	2	962462	SCREW, SHOULDER, .38 X 1.75, SS
9	1	854103	HOSE, VACUUM, 1.5INCH
10	1	853308	FITTING, MODIFIED
11	1	854102	HOSE, SQUEEGEE, 90 CUFF
12	1	858506	STRAP SUPPORT HOSE
13	1	851501	CAP HOSE DRAIN - REPL FOR 854101
14	1	854101	HOSE, DRAIN, CAPPED
15	4	962204	SCREW HH .25-20 X .75 SS W PATCH
16	8	980002	WASHER, LOCK, SPLIT, .25
17	9	W104D	WASHER, FLAT, .25
18	1	854501	HINGE, TANK, RECOVERY
19	2	852101	CLAMP, WIRE, P-SHAPED
20	1	853310	FOAM BARRIER NOISE
21	2	853305	FOAM, NOISE, VACUUM
22	1	855205	MOTOR VAC 24VDC PERIPH
23	4	964224	SCREW, PAN, #10 X .5, SELF TAPPING
24	1	873314	GASKET, FOAM, VACUUM
25	1	850819	BRACKET MOUTING VACUUM
26	2	920037	NUT, THIN JAM, 1/4-20, ZINC
27	1	852409	CABLE RETENTION TANK S-20 LONG
28	4	W189D	SCREW, HEX, 1/4-20 X .75, SS, PATCH
29	1	854105	HOSE SQUEEGEE S-20 CHEM RESIST
30	1	854104	HOSE DRAIN CAPPED CHEM RESIST

AVAILABLE VACUUM MOTOR KIT - #855019

ITEM	DESCRIPTION	QTY
857802	SHEET INSTRUCTION S-20 VAC MTR REPL	1
853305	FOAM,NOISE,VACUUM	2
911104	TIE-CABLE 14.5 LG 9531 H400014 H400002	4
873314	GASKET, FOAM, VACUUM	1
853310	FOAM BARRIER NOISE	1
855205	MTR, VAC,24VDC,2STG - KIT 855019 AVAIL	1

SQUEEGEE LINKAGE

ITEM	QTY	PART NUMBER	DESCRIPTION
1	1	850816	BRACKET LINK SQUEEGEE S-20
2	2	545010	KNOB KIT WEIGHT RETENTION
3	2	962464	SCREW, BUTTON, .31-18X1.25, ZINC
4	8	980105	WASHER, PLASTIC, THRUST
5	2	920040	NUT, .31-18, NYLOCK, SS, LOW
6	4	920036	NUT, NYLOCK, 5/16-18, SS
7	1	850501	AXLE, WHEEL, SQUEEGEE
8	2	849709	WHEEL, 2 OD, .31 ID
9	1	962075	SCREW, HEX, 3/8-16 X 1.5, SS
10	2	858204	SPACER, LINK, SQUEEGEE
11	1	902051	BEARING, ROD END, .38 FEM
12	1	920032	NUT .38-16 NYLOCK THIN ZINC
13	1	980003	WASHER, FLAT, .38
14	1	980009	WASHER, SPLIT LOCK, 3/8, SS
15	1	878504	STRAP, GROUNDING, STATIC
16	1	962028	SCREW, HX, .38-24X.75,SS,PTCH

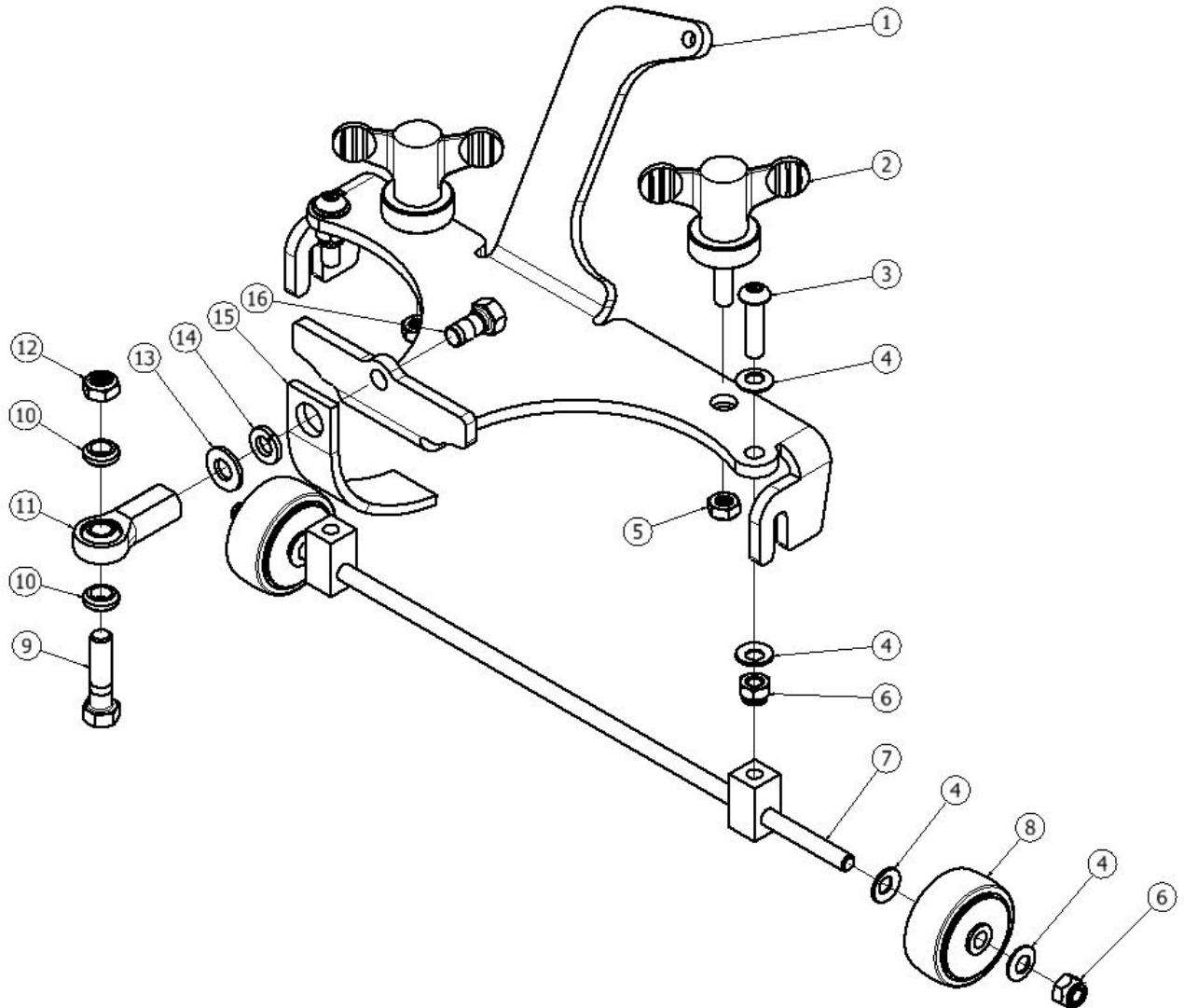

SQUEEGEE ASSEMBLY

LINATEX ASSEMBLY: 878516
URETHANE ASSEMBLY: 878517

ITEM	QTY	PART NUMBER	DESCRIPTION
1	1	853203	FRAME, SQUEEGEE, 30 INCH
2	1	850702	BLADE, REAR, 30 INCH
3	1	857201	RETAINER, REAR, 30 INCH
4	1	850701	BLADE, FRONT, 30 INCH
5	1	857202	RETAINER, FRONT, 30 INCH
6	2	852002	CLAMP, OVER-CENTER, BAND
7	4	920034	NUT, NYLOCK, #6-32, SS
8	2	962465	SCREW, SHOULDER, .50 X .50
9	2	859703	WHEEL, GUIDE
10	2	920035	NUT, NYLOCK, .38-16, SS
11	1	850704	BLADE, REAR, 30 IN, URETH (OPTIONAL)
12	1	850703	BLADE, FRONT, 30 INCH, URETH (OPTL)
13	2	980093	WASHER, WAVE, .50INCH

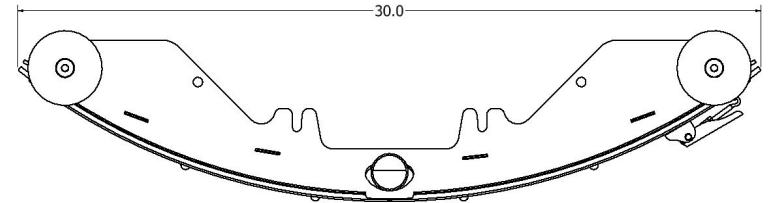

FRONT BLADE LENGTH: 31"
REAR BLADE LENGTH: 32-1/4"

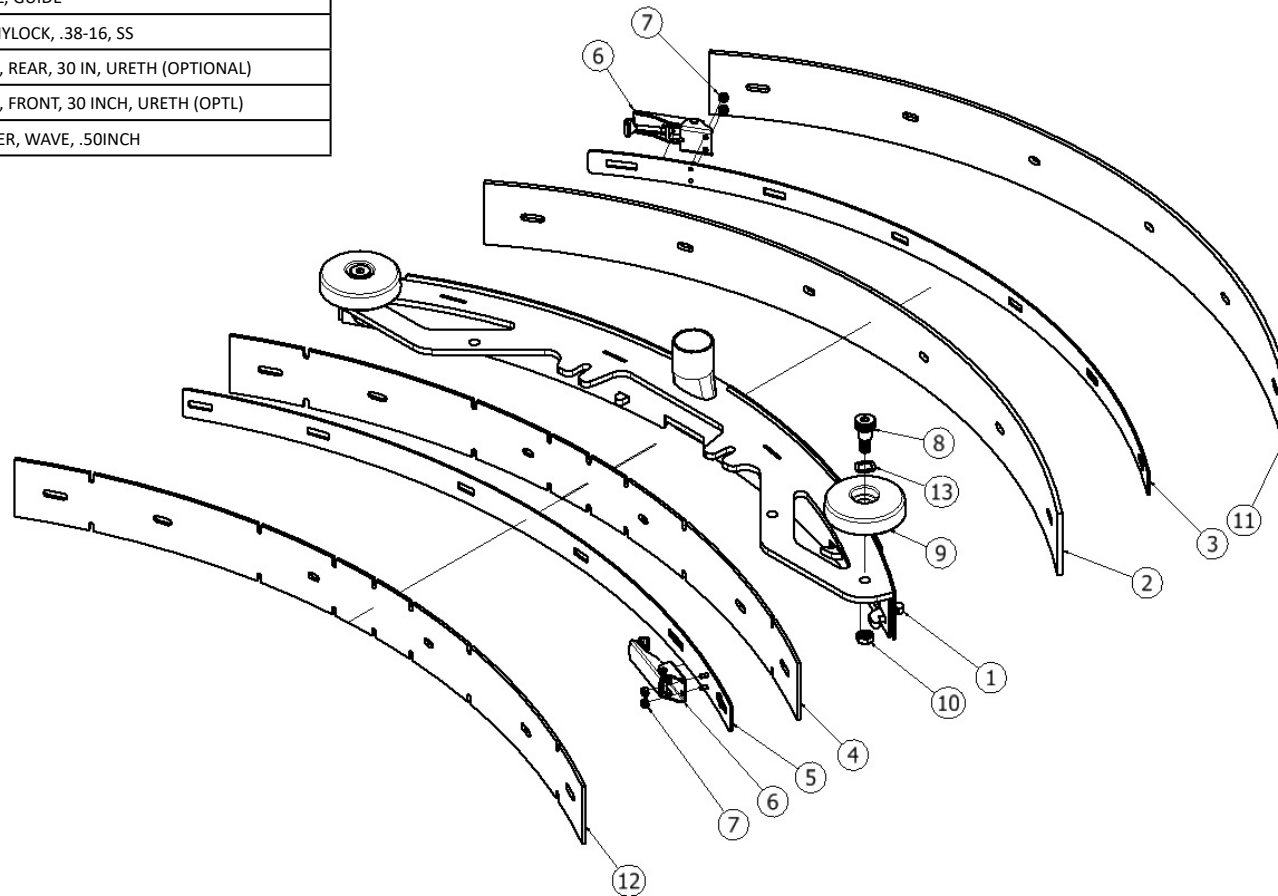

RETURN TO
TABLE OF
CONTENTS

ON-BOARD CHARGER (OPTIONAL)

ITEM	QTY	PART NUMBER	DESCRIPTION
1	1	850804	BRACKET, MTG, CHARGER
2	2	W189D	SCREW, HEX, 1/4-20 X .75, SS, PATCH
3	2	980002	WASHER, LOCK, SPLIT, .25
4	2	W104D	WASHER, FLAT, .25
5	1	852407	CHARGER, 24V, ONBRD, CULUS
6	4	962186	SCREW, PAN, #10-32 X 1.0, SS
7	4	W401D	WASHER, FLAT, #10
8	4	920666	NUT, NYLOCK, #10-32, SS
9	1	920034	NUT, NYLOCK, #6-32, SS
10	1	W132D	SCREW, PAN, #6-32 X 1.0, ZINC
11	1	850805	BRACKET, MTG, CORD
12	2	962263	SCREW, BUTT, SOCK, .25-20X.62, SS BO
13	1	911645	HARNESS, CHARGER, POST
14	2	852101	CLAMP, WIRE, P-SHAPED
15	2	501210	BUMPER

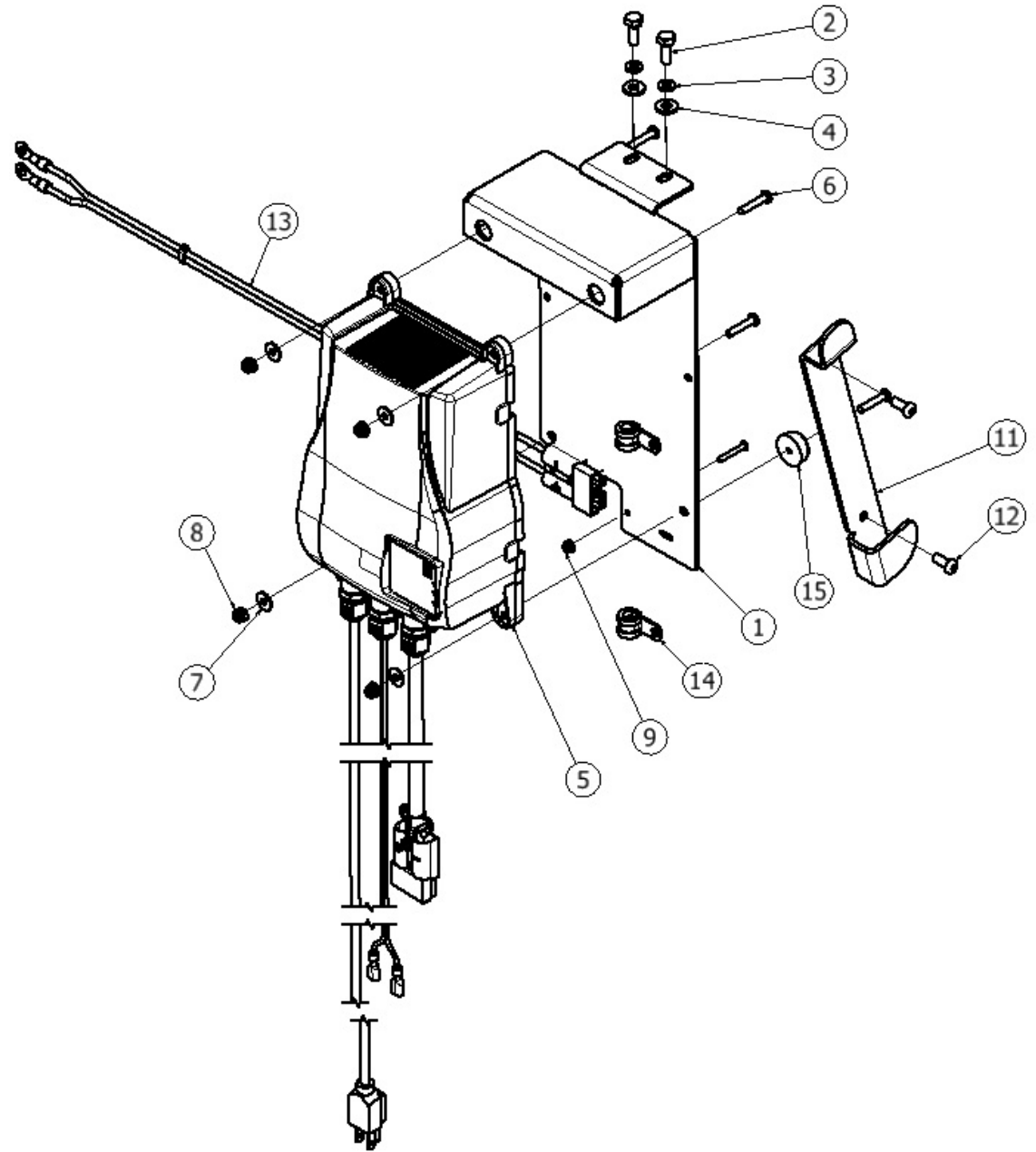

PAGE INTENTIONALLY BLANK

PAD ASSIST DISK SCRUB HEAD

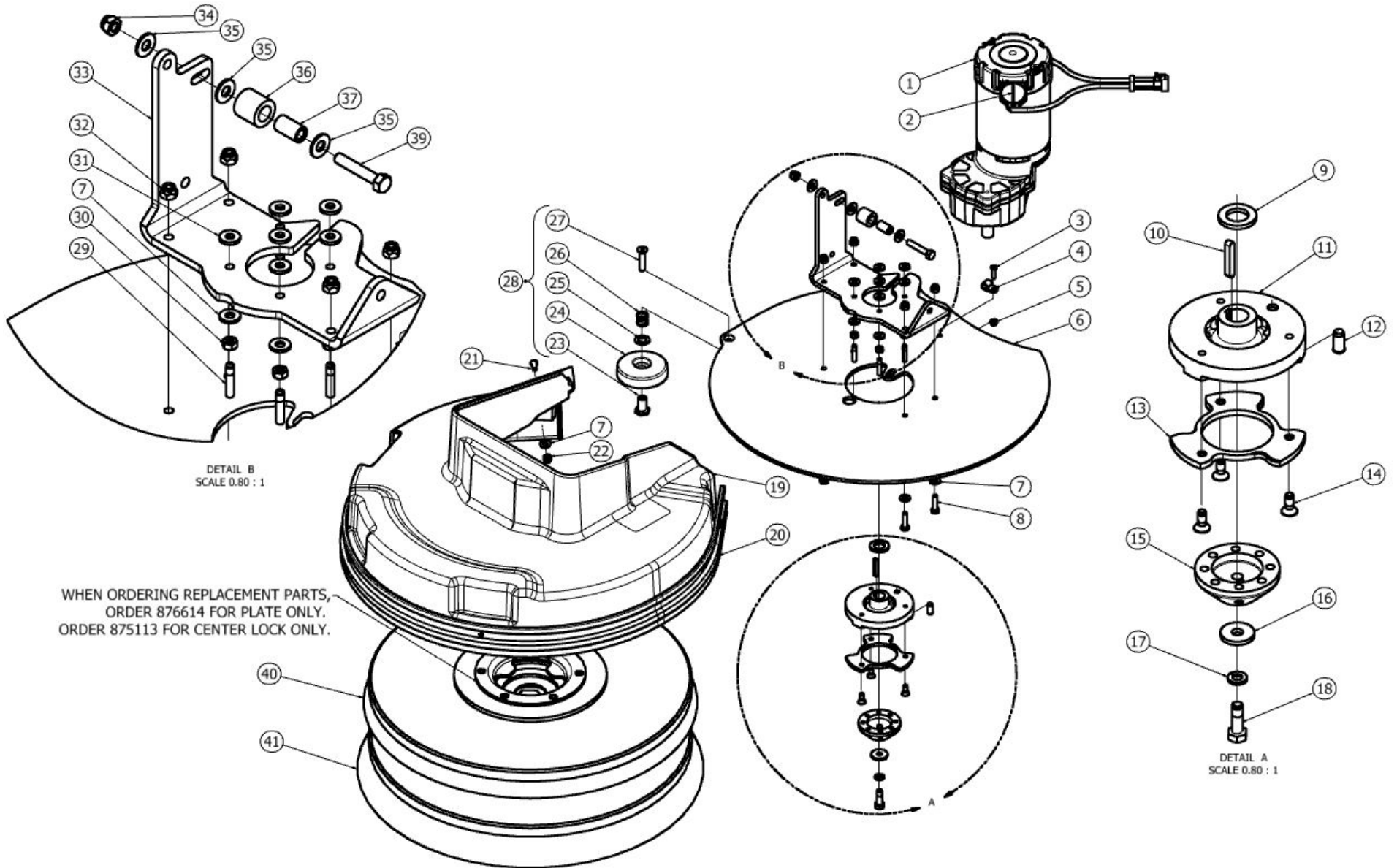

PAD ASSIST DISK SCRUB HEAD

ITEM	QTY	PART NUMBER	DESCRIPTION
1	1	855201	MOTOR, GEAR, BRUSH
2	1	850905	BRUSH CARBON KIT 2 PC 855201
3	1	962003	SCREW, PAN, #10-32 X .75, ZINC
4	1	612001	CLAMP, PLASTIC, P-SHAPED
5	1	920666	NUT, NYLOCK, #10-32, SS
6	1	856602	PLATE, MTG, MOTOR
7	12	W104D	WASHER, FLAT, .25
8	4	962221	SCREW, HEX, .25-20 X 1.0, SS
9	1	858201	SPACER, DRIVER, ROUND
10	1	915005	KEY, SQUARE, 5MM X 1.25
11	1	854302	HUB, DRIVER, BRUSH
12	1	857009	PLUNGER BALL PRESS-IN
13	1	853803	GUIDE, DRIVER
14	3	962274	SCREW, FLAT, SOCK, .25-20X.62, SS, PATCH
15	1	853804	GUIDE, PAD, PLASTIC
16	1	980107	WASHER, FLAT, .31ID, 1.0OD, .12THK, SS
17	1	980094	WASHER, SPLIT LOCK, .31, SS
18	1	962466	SCREW, HEX, M8-1.25 X 25, SS, PATCH
19	1	852302	SHROUD, HEAD, CUTOUT
20	1	858503	SKIRT, BRISTLE
21	4	962263	SCREW, BUTT, SOCK, .25-20X.62, SS BO
22	4	920665	NUT, NYLOCK, 1/4-20, SS
23	1	878209	SPACER WHEEL GUIDE
24	1	859703	WHEEL, GUIDE
25	1	980643	WASHER NYLON 1/2 ID
26	1	878302	SPRING COMPR .62L X .66DIA
27	1	962266	SCREW, FLAT, SOCKET, .31-18 X 1.5, SS
28	1	855022	KIT GUIDE WHEEL REPLACEMENT ANTIRATTLE
29	4	964010	SCREW, SET, M6 X 30, SS, PATCH
30	4	924082	NUT, NYLOCK, M6X1.0, SS
31	6	980784	WASHER .26 ID .094 THICK SS

ITEM	QTY	PART NUMBER	DESCRIPTION
32	4	920011	NUT, NYLOCK, 1/4-20, ZINC
33	1	850808	BRACKET, SUPPORT, HEAD
34	1	920012	NUT, NYLOCK, 5/16-18, ZINC
35	3	W243D	WASHER, FLAT, 5/16, SS
36	1	857501	ROLLER, PLASTIC
37	1	858203	SPACER, WHEEL, GUIDE
38	4	980002	WASHER, LOCK, SPLIT, .25
39	1	962270	SCREW, HEX, 5/16-18X1.75,SS
40	1	855901	DRIVER, PAD, 20INCH, BRISTLE
41	1	850901	BRUSH, POLY, 20 INCH
41	1	850902	BRUSH, NYLON, 20 INCH
41	1	850903	BRUSH, GRIT, 20 INCH
42	1	855016	KIT SHROUD REPLACEMENT (ITEMS 7, 19-22)

TRACTION DISK SCRUB HEAD

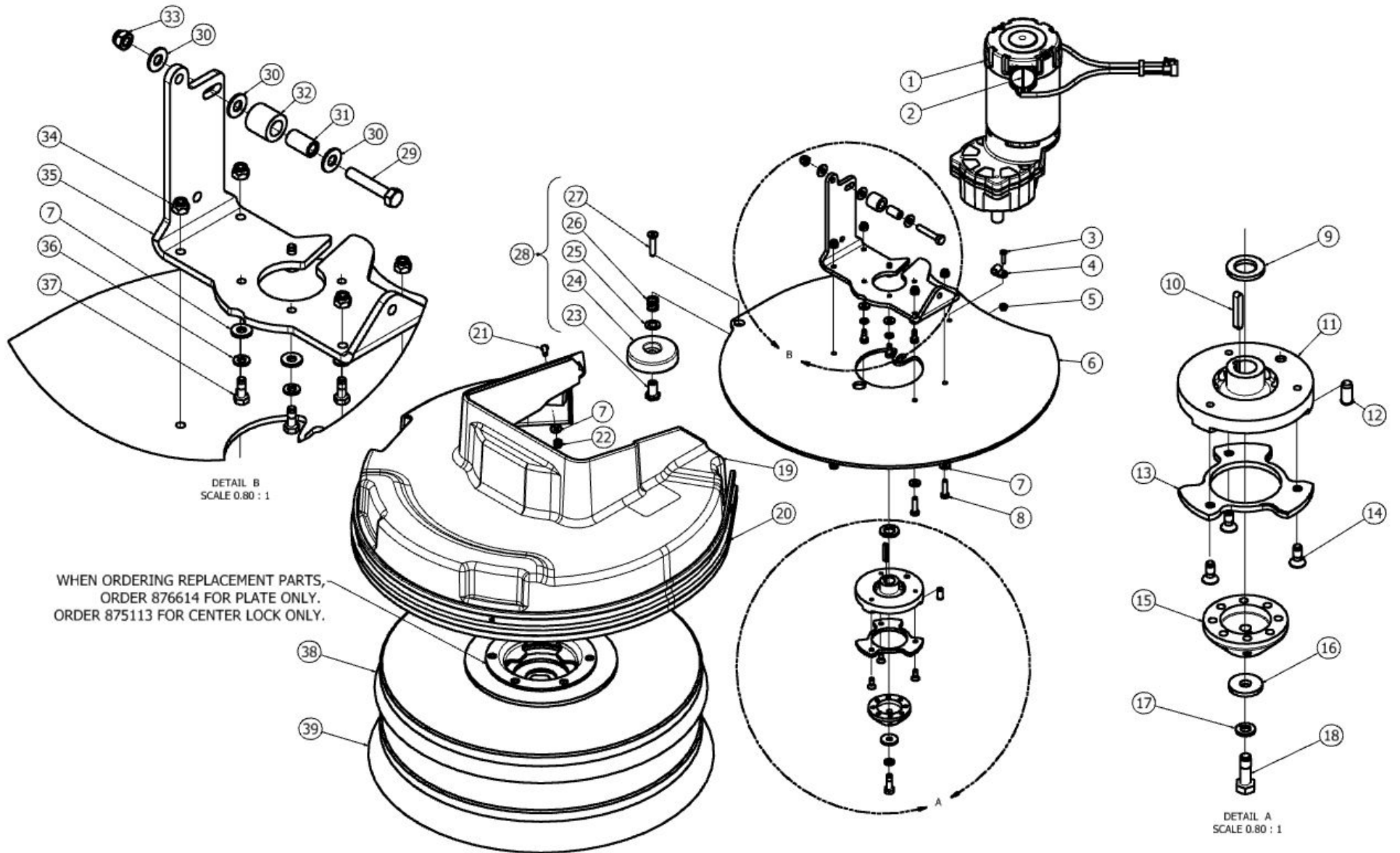

TRACTION DISK SCRUB HEAD

ITEM	QTY	PART NUMBER	DESCRIPTION
1	1	855201	MOTOR, GEAR, BRUSH
2	1	850905	BRUSH CARBON KIT 2 PC 855201
3	1	962003	SCREW, PAN, #10-32 X .75, ZINC
4	1	612001	CLAMP, PLASTIC, P-SHAPED
5	1	920666	NUT, NYLOCK, #10-32, SS
6	1	856602	PLATE, MTG, MOTOR
7	12	W104D	WASHER, FLAT, .25
8	4	962221	SCREW, HEX, .25-20 X 1.0, SS
9	1	858201	SPACER, DRIVER, ROUND
10	1	915005	KEY, SQUARE, 5MM X 1.25
11	1	854302	HUB, DRIVER, BRUSH
12	1	857009	PLUNGER BALL PRESS-IN
13	1	853803	GUIDE, DRIVER
14	3	962274	SCREW, FLAT, SOCK, .25-20X.62, SS, PATCH
15	1	853804	GUIDE, PAD, PLASTIC
16	1	980107	WASHER, FLAT, .31ID, 1.0OD, .12THK, SS
17	1	980094	WASHER, SPLIT LOCK, .31, SS
18	1	962466	SCREW, HEX, M8-1.25 X 25, SS, PATCH
19	1	852302	SHROUD, HEAD, CUTOUT
20	1	858503	SKIRT, BRISTLE
21	4	962263	SCREW, BUTT, SOCK, .25-20X.62, SS BO
22	4	920665	NUT, NYLOCK, 1/4-20, SS
23	1	878209	SPACER WHEEL GUIDE
24	1	859703	WHEEL, GUIDE
25	1	980643	WASHER NYLON 1/2 ID
26	1	878302	SPRING COMPR .62L X .66DIA
27	1	962266	SCREW, FLAT, SOCKET, .31-18 X 1.5, SS
28	1	855022	KIT GUIDE WHEEL REPLACEMENT ANTIRATTLE
29	1	962270	SCREW, HEX, 5/16-18X1.75,SS
30	3	W243D	WASHER, FLAT, 5/16, SS
31	1	858203	SPACER, WHEEL, GUIDE

ITEM	QTY	PART NUMBER	DESCRIPTION
32	1	857501	ROLLER, PLASTIC
33	1	920012	NUT, NYLOCK, 5/16-18, ZINC
34	4	920011	NUT, NYLOCK, 1/4-20, ZINC
35	1	850808	BRACKET, SUPPORT, HEAD
36	4	980002	WASHER, LOCK, SPLIT, .25
37	4	964448	SCREW, HEX, M6 X 16, SS, PATCH
38	1	855901	DRIVER, PAD, 20INCH, BRISTLE
39	1	850901	BRUSH, POLY, 20 INCH
39	1	850902	BRUSH, NYLON, 20 INCH
39	1	850903	BRUSH, GRIT, 20 INCH
40	1	855016	KIT SHROUD REPLACEMENT (ITEMS 7, 19-22)

S-20HD DISK SCRUB HEAD

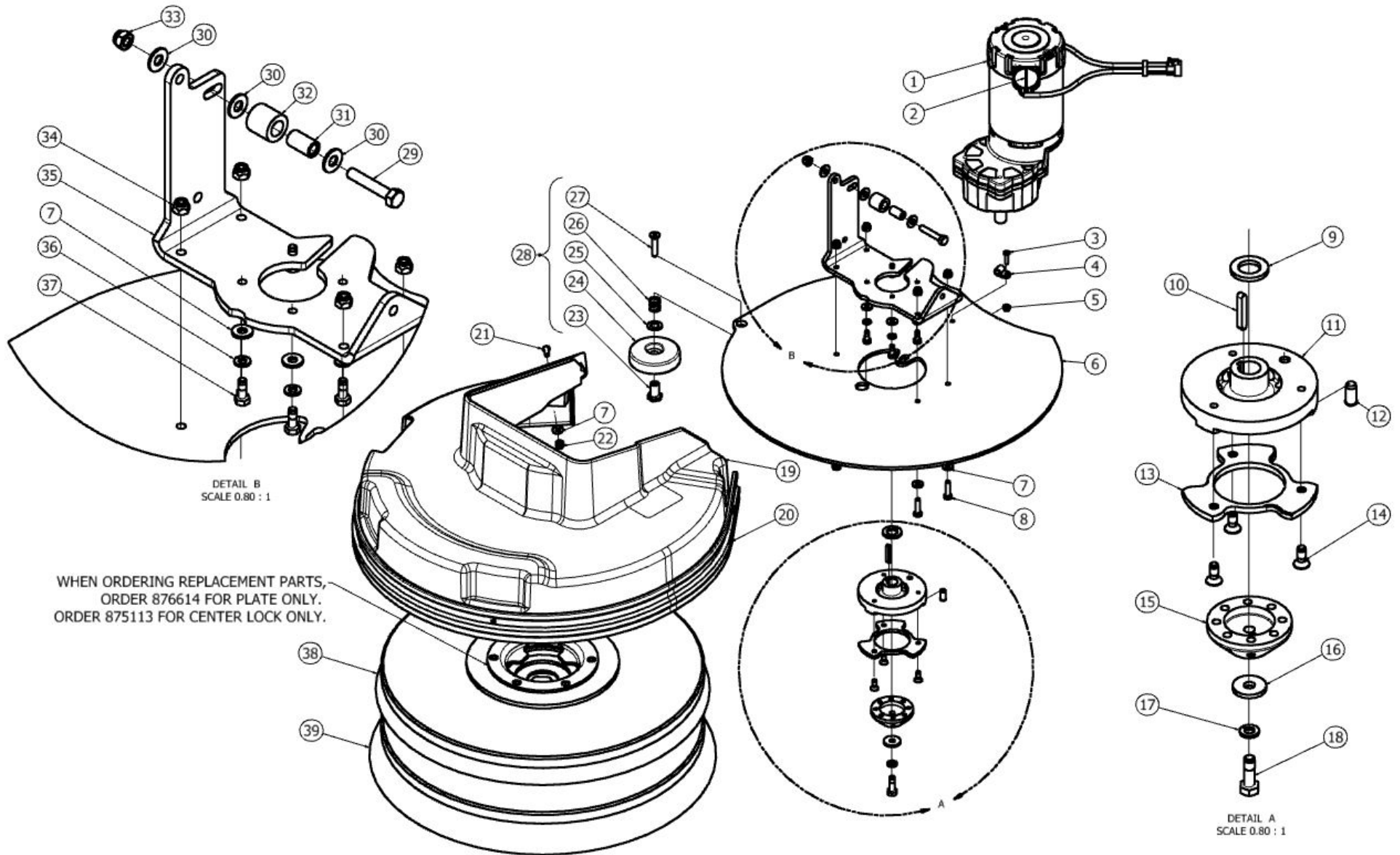

S-20HD DISK SCRUB HEAD

ITEM	QTY	PART NUMBER	DESCRIPTION
1	1	855207	MOTOR, GEAR, BRUSH
2	1	850905	BRUSH CARBON KIT 2 PC 855201
3	1	962003	SCREW, PAN, #10-32 X .75, ZINC
4	1	612001	CLAMP, PLASTIC, P-SHAPED
5	1	920666	NUT, NYLOCK, #10-32, SS
6	1	856602	PLATE, MTG, MOTOR
7	12	W104D	WASHER, FLAT, .25
8	4	962221	SCREW, HEX, .25-20 X 1.0, SS
9	1	858201	SPACER, DRIVER, ROUND
10	1	915005	KEY, SQUARE, 5MM X 1.25
11	1	854302	HUB, DRIVER, BRUSH
12	1	857009	PLUNGER BALL PRESS-IN
13	1	853803	GUIDE, DRIVER
14	3	962274	SCREW, FLAT, SOCK, .25-20X.62, SS, PATCH
15	1	853804	GUIDE, PAD, PLASTIC
16	1	980107	WASHER, FLAT, .31ID, 1.0OD, .12THK, SS
17	1	980094	WASHER, SPLIT LOCK, .31, SS
18	1	962466	SCREW, HEX, M8-1.25 X 25, SS, PATCH
19	1	852302	SHROUD, HEAD, CUTOUT
20	1	858503	SKIRT, BRISTLE
21	4	962263	SCREW, BUTT, SOCK, .25-20X.62, SS BO
22	4	920665	NUT, NYLOCK, 1/4-20, SS
23	1	878209	SPACER WHEEL GUIDE
24	1	859703	WHEEL, GUIDE
25	1	980643	WASHER NYLON 1/2 ID
26	1	878302	SPRING COMPR .62L X .66DIA
27	1	962266	SCREW, FLAT, SOCKET, .31-18 X 1.5, SS
28	1	855022	KIT GUIDE WHEEL REPLACEMENT ANTIRATTLE
29	1	962270	SCREW, HEX, 5/16-18X1.75,SS
30	3	W243D	WASHER, FLAT, 5/16, SS
31	1	858203	SPACER, WHEEL, GUIDE

ITEM	QTY	PART NUMBER	DESCRIPTION
32	1	857501	ROLLER, PLASTIC
33	1	920012	NUT, NYLOCK, 5/16-18, ZINC
34	4	920011	NUT, NYLOCK, 1/4-20, ZINC
35	1	850808	BRACKET, SUPPORT, HEAD
36	4	980002	WASHER, LOCK, SPLIT, .25
37	4	964448	SCREW, HEX, M6 X 16, SS, PATCH
38	1	855901	DRIVER, PAD, 20INCH, BRISTLE
39	1	850901	BRUSH, POLY, 20 INCH
39	1	850902	BRUSH, NYLON, 20 INCH
39	1	850903	BRUSH, GRIT, 20 INCH
40	1	855016	KIT SHROUD REPLACEMENT (ITEMS 7, 19-22)

ORBITAL SCRUB HEAD

PRIOR TO SERIAL NUMBER 123986 – CONFIRM SERIAL NUMBER BEFORE ORDERING REPLACEMENT PARTS

ITEM	QTY	PART NUMBER	DESCRIPTION
1	1	NONE	SUB ASSY - HEAD, 20 INCH, ORBITAL
2	1	850813	BRACKET, MTG, HEAD, ORBITAL
3	2	859703	WHEEL, GUIDE
4	1	858203	SPACER, WHEEL, GUIDE
5	1	856603	PLATE, MOUNTING, MOTOR
6	2	962266	SCREW, FLAT, SOCKET, .31-18 X 1.5, SS
7	3	W243D	WASHER, FLAT, 5/16, SS
8	4	964009	SCREW, SCK, FLT, M6-1 X 20, SS, PATCH
9	2	852003	CLAMP, P-SHAPED, .62 DIA
10	2	962263	SCREW, BUTT, SOCK, .25-20X.62, SS BO
11	6	920665	NUT, NYLOCK, 1/4-20, SS
12	8	851101	BUSHING, RUBBER
13	4	858205	SPACER, RUBBER
14	1	857501	ROLLER, PLASTIC
15	1	855204	MOTOR, 24V, 2200 RPM, 1HP
16	1	850906	BRUSH CARBON KIT 4 PC 855204 & 875201
17	2	856611	PLATE, WEIGHT
18	4	W117D	SCREW, HEX, .25-20 X 2.0, SS
19	3	962270	SCREW, HEX, 5/16-18X1.75,SS
20	1	915006	KEY, 8MM X 7MM X 28MM
21	1	980093	WASHER, WAVE, .50INCH
22	8	980104	WASHER, RUBBER
23	4	980094	WASHER, SPLIT LOCK, .31, SS
24	4	W405D	NUT, .31-18, JAM, SS
25	3	920012	NUT, NYLOCK, 5/16-18, ZINC
26	1	855116	LABEL PATENT ORBITAL HEAD
27	1	859005	TUBE DISTRIBUTION S-20 ORB
28	2	856802	PLUG .62 TUBE
29	2	878302	SPRING COMPR .62L X .66DIA
30	2	878209	SPACER WHEEL GUIDE
31	2	980643	WASHER NYLON 1/2 ID

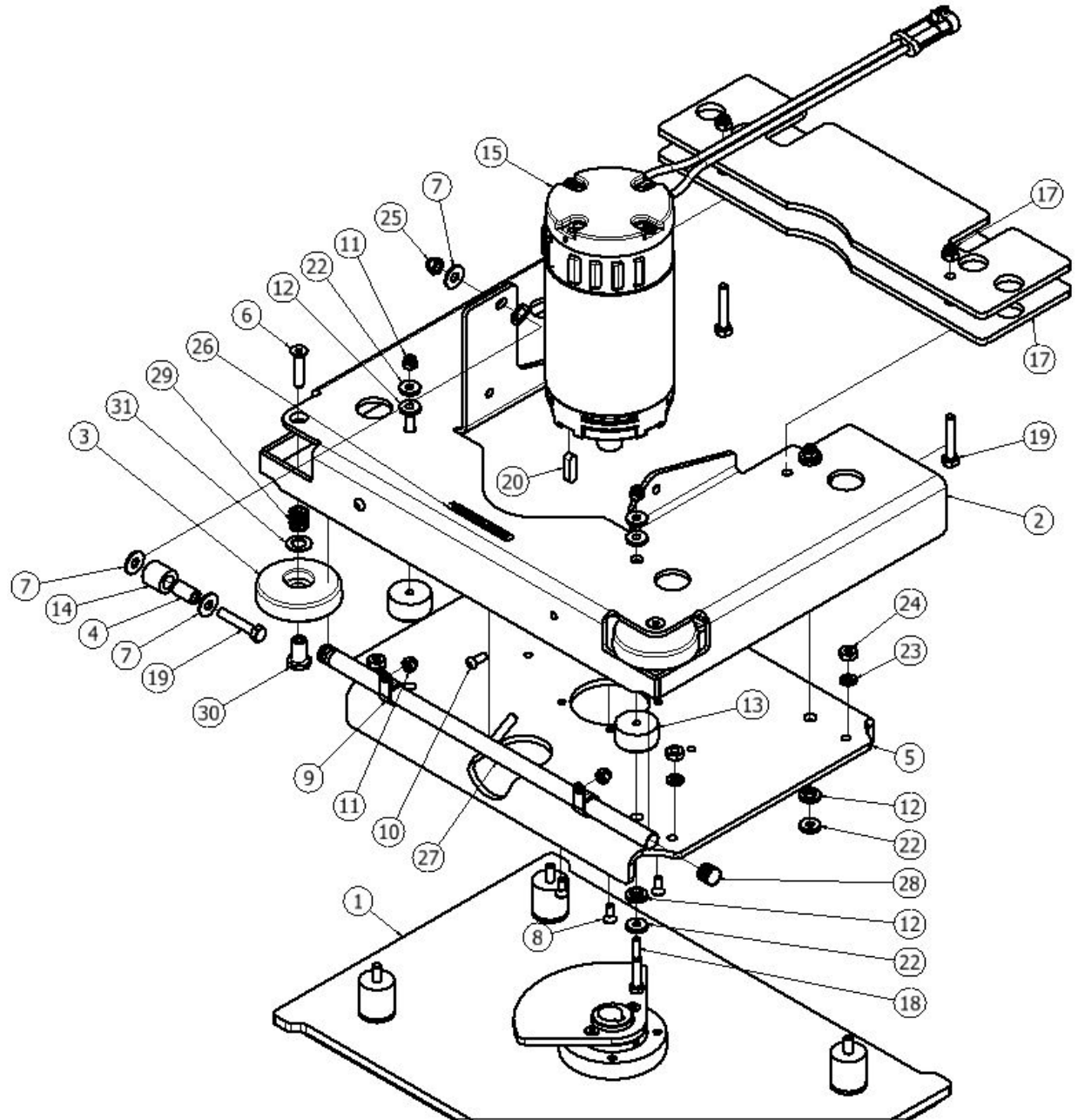

ORBITAL SCRUB HEAD

*** AFTER SERIAL NUMBER 123986 – CONFIRM SERIAL NUMBER BEFORE ORDERING REPLACEMENT PARTS ***

ITEM	QTY	PART NUMBER	DESCRIPTION
1	1	850813	BRACKET, MTG, HEAD, ORBITAL
2	2	878302	SPRING COMPR .62L X .66DIA
3	2	980643	WASHER NYLON 1/2 ID
4	2	859703	WHEEL, GUIDE
5	2	878209	SPACER WHEEL GUIDE
6	2	962263	SCREW BHCS .25-20 X .63 SS BL
7	1	859005	TUBE DISTRIBUTION S-20 ORB
8	2	852003	CLAMP, P-SHAPED, .62 DIA
9	1	856603	PLATE, MOUNTING, MOTOR
10	4	964009	SCREW FHCS M6 X 16 SS PATCH
11	4	W117D	SCREW HH .25-20 X 2 SS
12	8	980004	WASHER FLAT .25 ZINC
13	8	851101	BUSHING, RUBBER
14	4	980094	WASHER SPLIT LOCK .31 SS
15	4	W405D	NUT HEX .31-18 SS
16	4	858205	SPACER, RUBBER
17	2	856802	PLUG .62 TUBE
18	6	920665	NUT HEX .25-20 NYLOCK SS
19	2	962075	SCREW HH .38-16 X 1.5 SS
20	1	855116	LABEL PATENT ORBITAL HEAD
21	2	920032	NUT HEX .38-16 NYLOCK ZINC THIN
22	1	856616	PLATE WEIGHT
23	1	962270	SCREW HH .31-18 X 1.75 SS
24	1	915006	KEY, 8MM X 7MM X 28MM
25	3	W243D	WASHER, FLAT, 5/16, SS
26	1	980093	WASHER WAVE .50
27	1	858203	SPACER, WHEEL, GUIDE
28	1	857501	ROLLER, PLASTIC
29	1	855204	MOTOR, 24V, 2200 RPM, 1HP
30	1	920012	NUT HEX .31-18 NYLOCK ZINC
31	2	962266	SCREW FHCS .31-18 X 1.5 SS
32	1	855022	KIT GUIDE WHEEL REPLACEMENT ANTI-RATTLE
33	1	850906	BRUSH CARBON KIT 4 PC

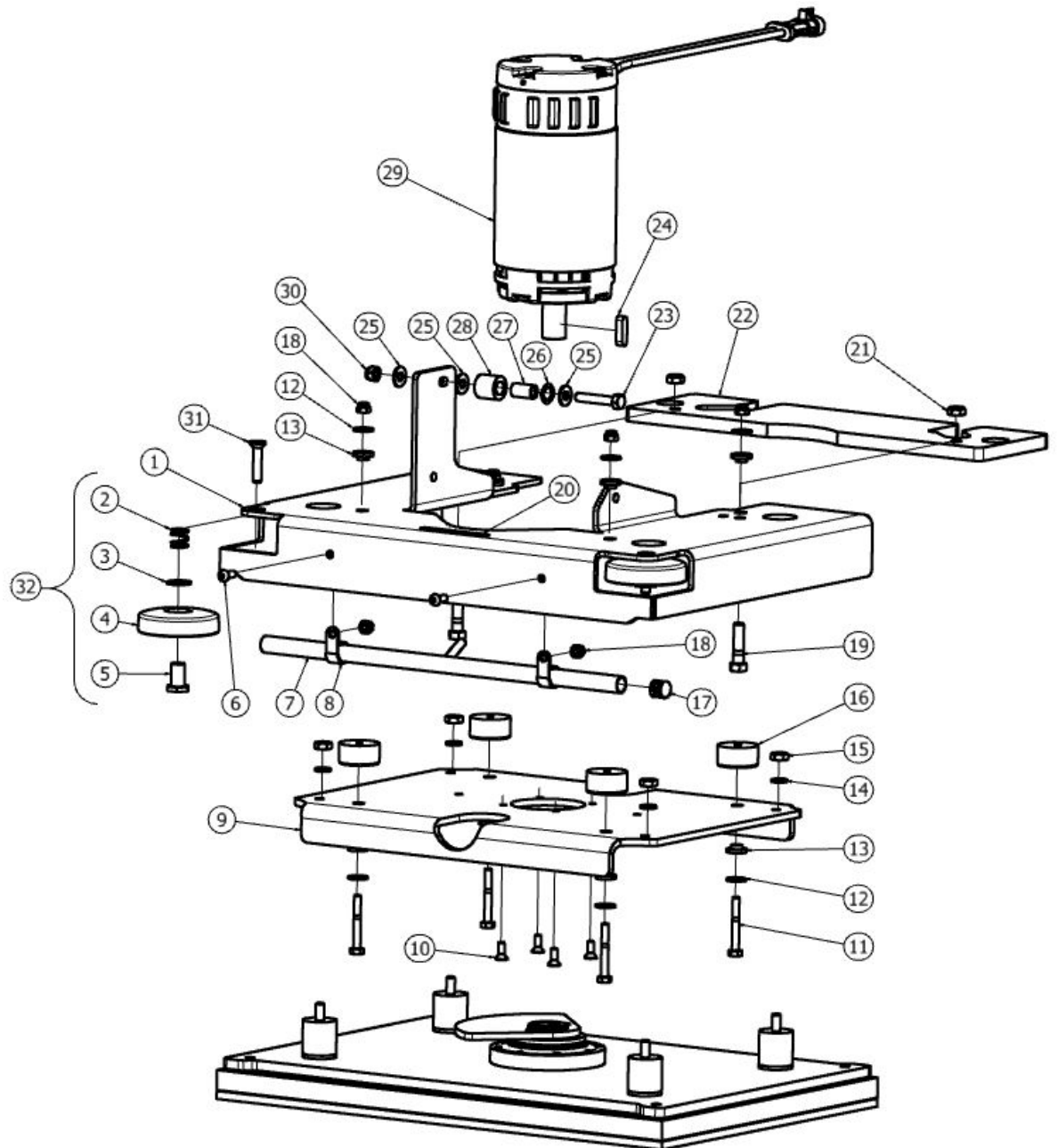

ORBITAL SCRUB HEAD

PRIOR TO SERIAL NUMBER 127077 – CONFIRM SERIAL NUMBER BEFORE ORDERING REPLACEMENT PARTS

ITEM	QTY	PART NUMBER	DESCRIPTION
1	1	855011	KIT, PLATE, REPL, ORBIT
2*	1	856604	PLATE, ORBITAL, 20 INCH
3*	1	875903	PAD, MIGHTYLOK ADH UNIVERSAL
4**	8	962278	SCREW, SOCKET, FLT, .31-18X.88, SS, PATCH
5**	4	980108	WASHER, FLAT, .31ID, 1.25OD, .12THK, SS
6**	4	855604	MOUNT, ISOLATOR, .31THD
7***	4	962274	SCREW, FLAT, SOCK, .25-20X.62, SS, PATCH
8***	1	856605	PLATE, RETAINER, BEARING
9***	1	N/A	ASSY, BEARING, ORBIT S-20
10***	1	962280	SCREW, SET, .25-20X.5, SS, PATCH
11	1	856606	PLATE, BALANCE, 20 INCH

*ITEMS 2 & 3 CAN BE ORDERED PRE-ASSEMBLED AS A KIT UNDER PART NUMBER 855011- KIT, PLATE, REPL, ORBIT.

**ITEMS 4, 5, & 6 CAN BE ORDERED AS A KIT UNDER PART NUMBER 855027 - KIT ISOLATOR SET OF 4 W/ STD HWD.

***ITEMS 7-10 CAN BE ORDERED AS A KIT UNDER PART NUMBER 855010 - ASSY, BEARING, REPL, ORBIT.

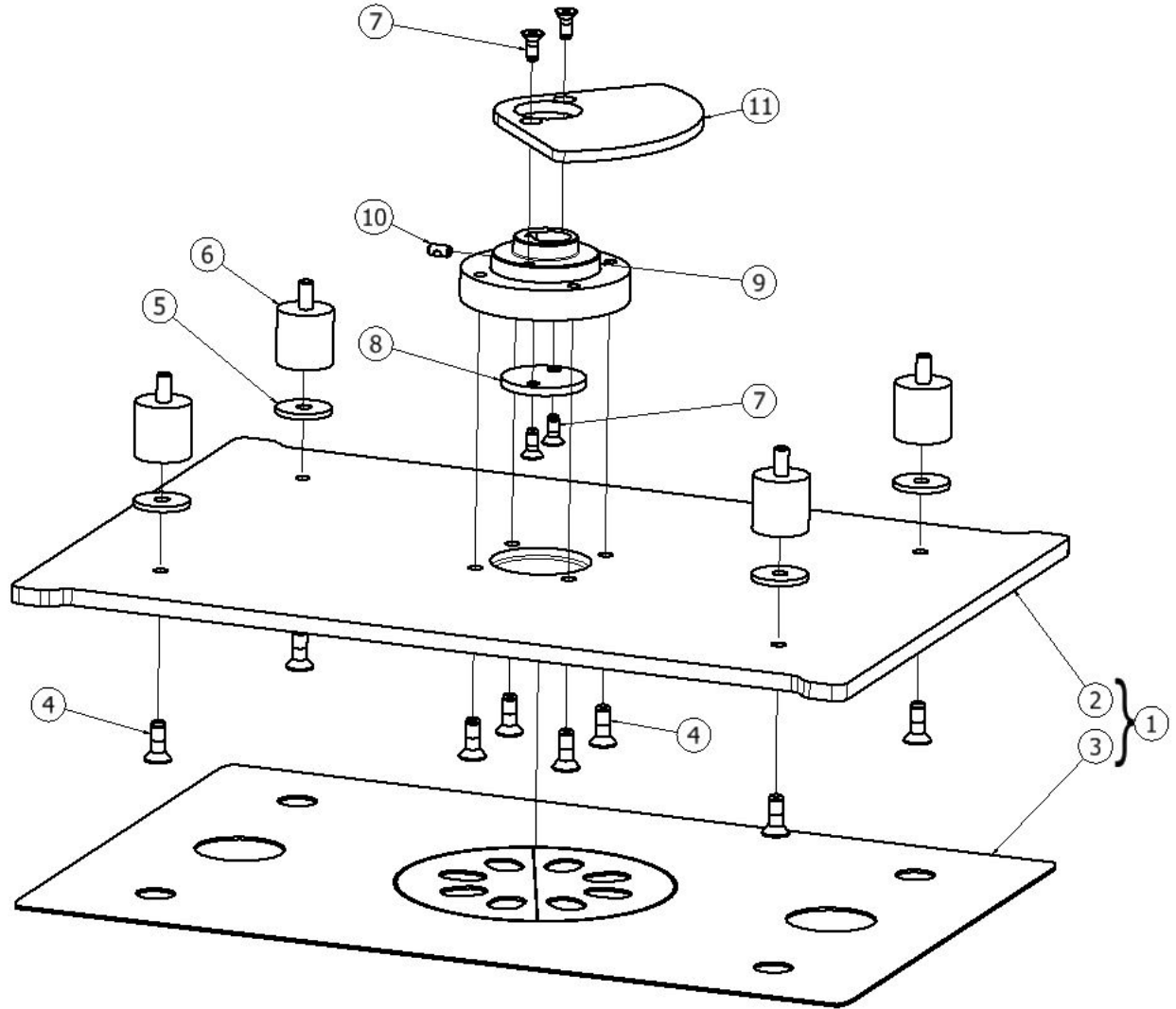

ORBITAL SCRUB HEAD

AFTER SERIAL NUMBER 127076 – CONFIRM SERIAL NUMBER BEFORE ORDERING REPLACEMENT PARTS

ITEM	QTY	PART NUMBER	DESCRIPTION
1*	1	856615	PLATE, ORBITAL, 20 INCH GEN 2
2*	1	875903	PAD, MIGHTYLOK ADH UNIVERSAL
3**	12	962278	SCREW, SOCKET, FLT, .31-18X.88, SS, PATCH
4**	4	980108	WASHER, FLAT, .31ID, 1.25OD, .12THK, SS
5**	4	855604	MOUNT, ISOLATOR, .31THD
6***	1	875801	O-RING, EPDM, 233
7***	4	962274	SCREW, FLAT, SOCK, .25-20X.62, SS, PATCH
8***	1	856605	PLATE, RETAINER, BEARING
9***	1	962280	SCREW, SET, .25-20X.5, SS, PATCH
10***	1	N/A	ASSY, BEARING, REPL, ORBIT S-20
11***	1	547604	SEAL BEARING ORBITAL
12	1	856606	PLATE, BALANCE, 20 INCH

*ITEMS 1 & 2 CAN BE ORDERED PRE-ASSEMBLED AS A KIT UNDER PART NUMBER 855031 - KIT ORB PLATE 20IN REPL GEN2.

**ITEMS 3, 4, & 5 CAN BE ORDERED AS A KIT UNDER PART NUMBER 855027 - KIT ISOLATOR SET OF 4 W/ STD HWD.

***ITEMS 6-11 CAN BE ORDERED AS A KIT UNDER PART NUMBER 855032 - KIT ORB BEARING 20IN REPL GEN2.

MACHINES PRIOR TO SERIAL NUMBER 127077 CAN BE UPGRADED TO THE NEW DESIGN BY ORDERING PART NUMBER 855033 - KIT ORB HEAD LOWER 20IN REPL GEN2.

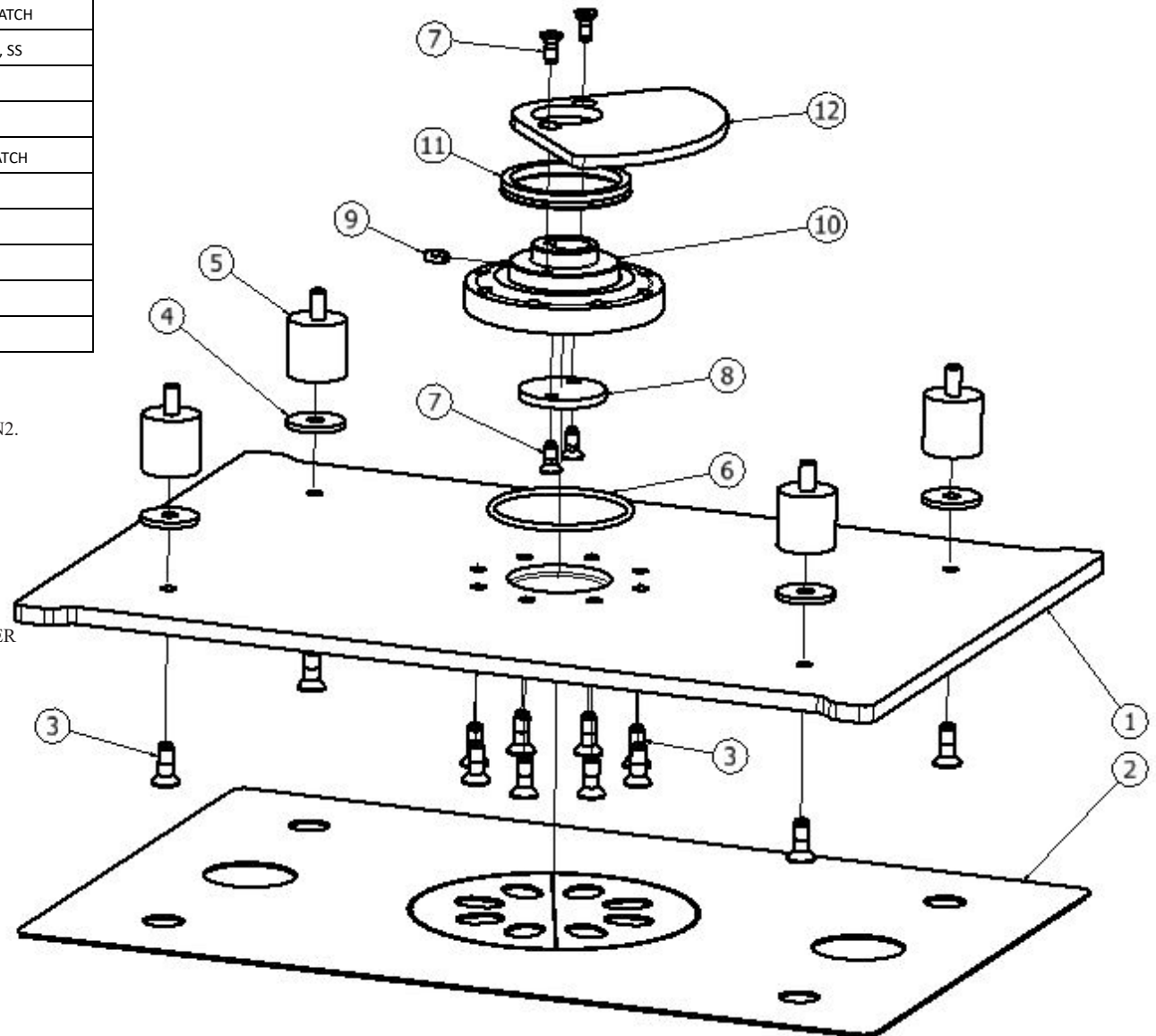

S-24XM SCRUB HEAD

ITEM	QTY	PART NUMBER	DESCRIPTION
1	1	876602	PLATE, MTG, 24 INCH
2	3	858203	SPACER, WHEEL, GUIDE
3	8	W104D	WASHER, FLAT, .25
4	9	W243D	WASHER, FLAT, 5/16, SS
5	1	853803	GUIDE, DRIVER
6	2	873801	GUIDE, PAD, PLASTIC
7	3	857501	ROLLER, PLASTIC
8	13	962274	SCREW, FLAT, SOCK, .25-20X.62, SS, PATCH
9	3	962270	SCREW, HEX, 5/16-18X1.75,SS
10	3	920012	NUT, NYLOCK, 5/16-18, ZINC
11	1	855204	MOTOR, 24V, 2200 RPM, 1HP
12	1	850906	BRUSH CARBON KIT 4 PC 855204 & 875201
13	1	903046	BELT, V-GROOVE, STRETCH
14	1	876606	PLATE, COVER, 24 INCH
15	2	877701	SHAFT, PULLEY, HEAD
16	6	902035	BEARING, .5 ID, 1.1875 OD
17	3	876901	PULLEY, IDLER
18	3	877302	RING, RETAINING, INT, 1.12 DIA
19	6	878201	SPACER, IDLER
20	3	878202	SPACER, IDLER, PLAIN
21	1	876902	PULLEY, MOTOR, DRIVE
22	1	980108	WASHER, FLAT, .31ID, 1.25OD, .12THK, SS
23	1	915006	KEY, 8MM X 7MM X 28MM
24	4	902053	BEARING, .75 ID, DBL SEAL
25	2	980003	WASHER, FLAT, .38
26	2	878203	SPACER, BEARING
27	1	874306	HUB, PULLEY, MACH GROOVED
28	1	874305	HUB, PULLEY, MACH FLAT
29	4	964008	SCREW, HEX, M6 X 25, SS, PATCH
30	1	964060	SCREW, HEX, M8-1.25 X 20, SS
31	2	920039	NUT, .62-18, NYLOCK, LOW
32	1	870814	BRACKET, SUPPORT, 24XM
33	2	920035	NUT, NYLOCK, .38-16, SS
34	1	873802	GUIDE, DRIVER, RH
35	1	878206	SPACER, MOTOR, 24INCH
36	6	W189D	SCREW, HEX, 1/4-20 X .75, SS, PATCH
37	6	980002	WASHER, LOCK, SPLIT, .25
38	2	857009	PLUNGER BALL PRESS-IN

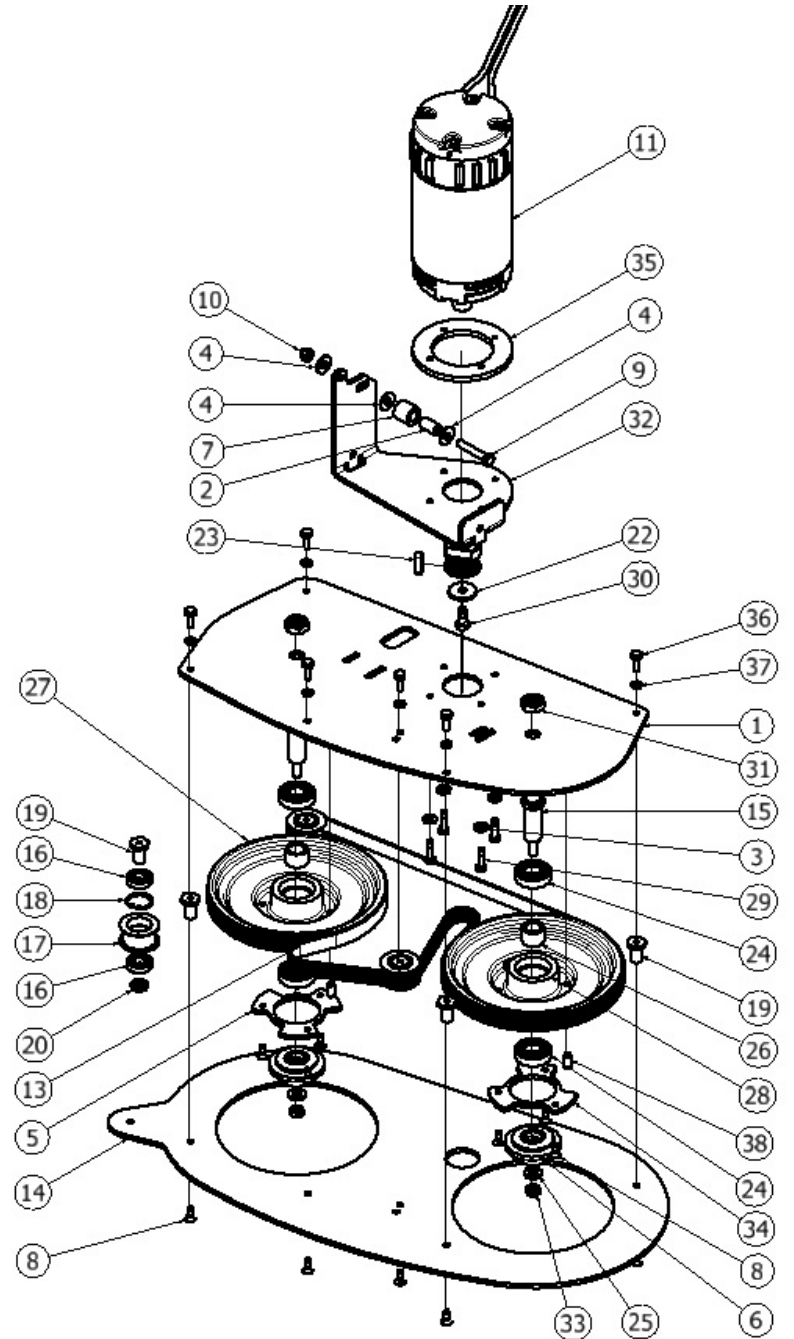

RETURN TO
TABLE OF
CONTENTS

S-24XM SCRUB HEAD

ITEM	QTY	PART NUMBER	DESCRIPTION
1	2	870902	BRUSH, POLY, 12 INCH
2	2	870908	BRUSH, NYLON, 12 INCH
3	2	870909	BRUSH, GRIT, 12 INCH
4	1	859703	WHEEL, GUIDE
5	1	875019	KIT SKIRT REPLACEMENT (ITEMS 6 - 10)
6	4	962263	SCREW, BUTT, SOCK, .25-20X.62, SS BO
7	4	920665	NUT, NYLOCK, 1/4-20, SS
8	8	W104D	WASHER, FLAT, .25
9	1	872305	SHROUD, HEAD, 24INCH
10	1	858503	SKIRT, BRISTLE
11	2	873302	FITTING, TEE, PM02XBM04
12	2	875901	DRIVER, PAD, 12INCH, BRISTLE
13	1	204179 - 16.0"	TUBING, 1/4"
14	1	204179 - 9.75"	TUBING, 1/4"
15	1	204179 - 8.25"	TUBING, 1/4"
16	1	873308	FITTING, TEE, 0.50 INCH
17	2	853301	FITTING, REDUCER, BM08, BM04
18	2	224130 - 1.75"	TUBING, 1/2"
19	1	878205	SPACER, WHEEL, GUIDE
20	1	224130 - 20.0"	TUBING, 1/2"
21	1	962274	SCREW, FLAT, SOCK, .25-20X.62, SS, PATCH

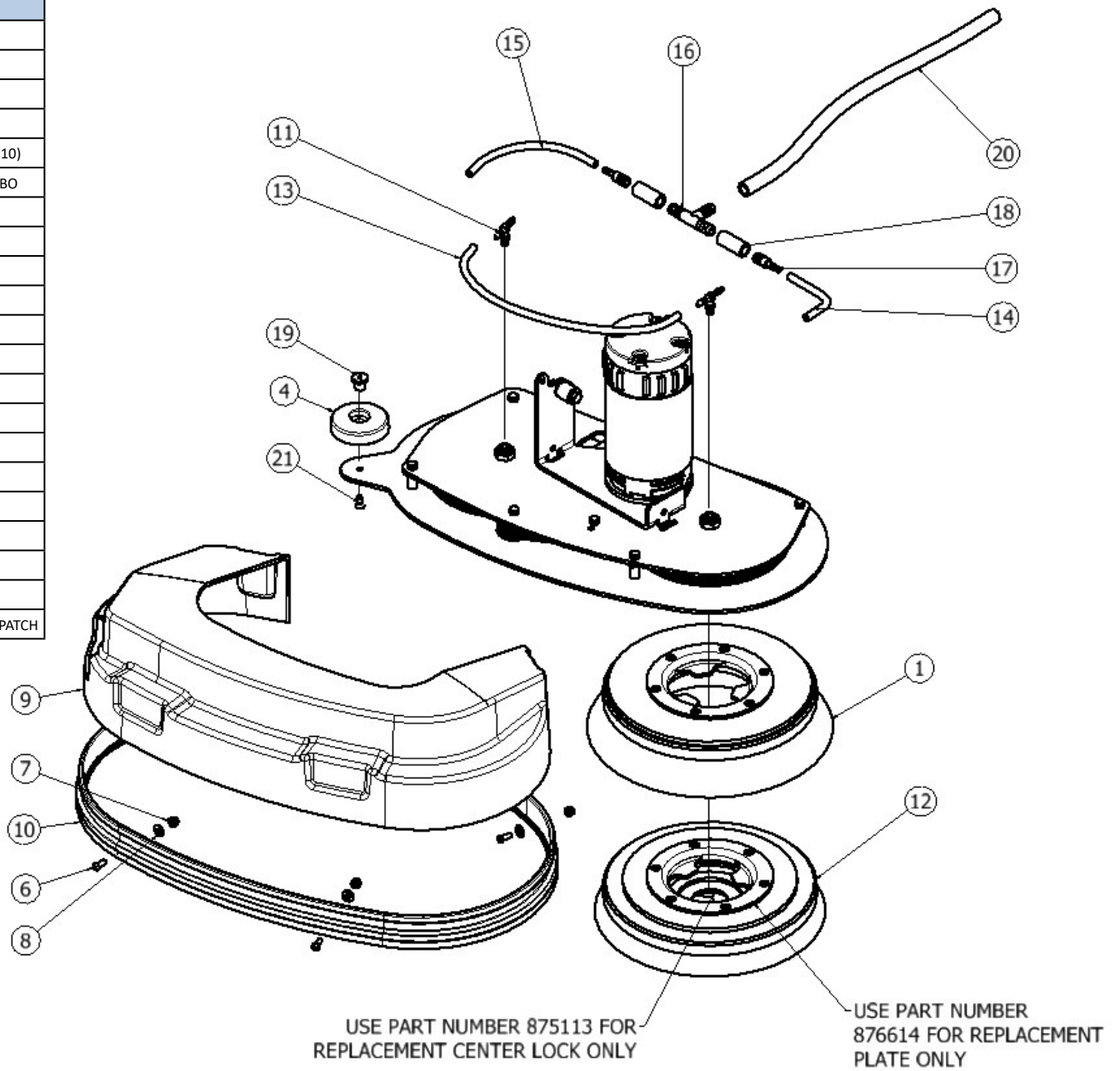

S-20 TRACTION (DISK) & S-24XM ***PRIOR TO SERIAL NUMBER 113191***

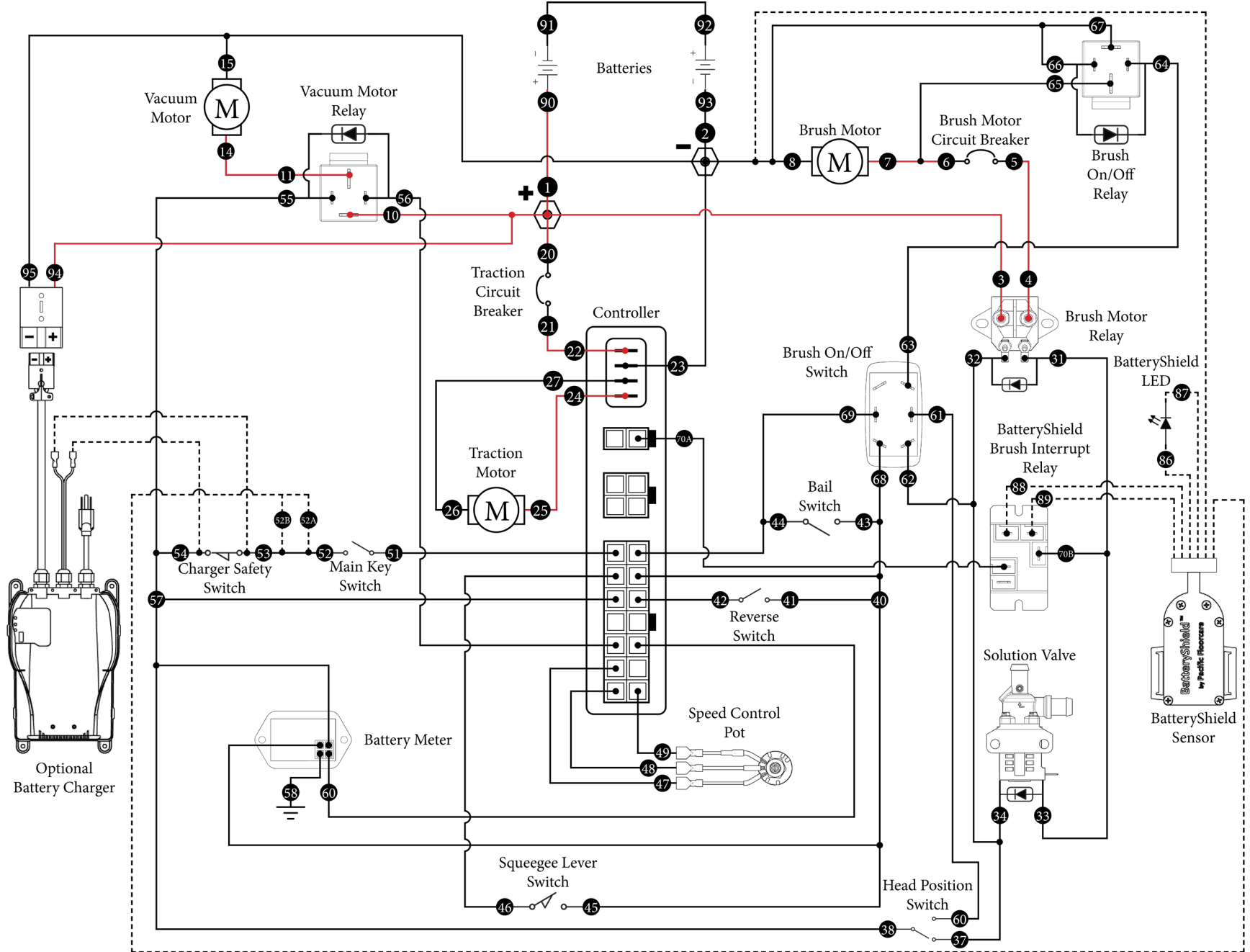

----- Wires represented with dashed lines indicate optional equipment installation

RETURN TO
TABLE OF
CONTENTS

S-20 TRACTION (DISK) & S-24XM ***AFTER SERIAL NUMBER 113191***

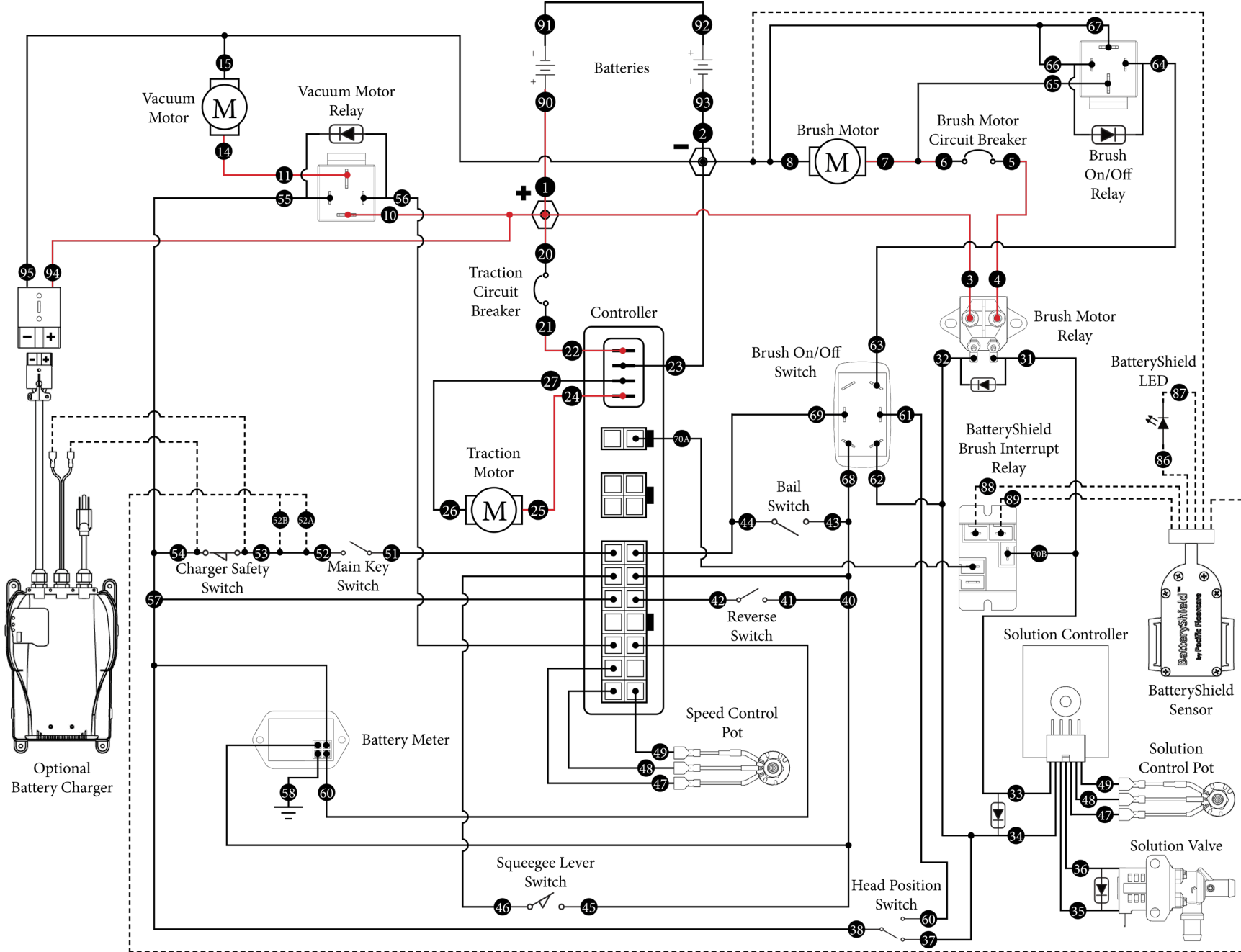

--- Wires represented with dashed lines indicate optional equipment installation

RETURN TO
TABLE OF
CONTENTS

S-20 ORBITAL

PRIOR TO SERIAL NUMBER 113191

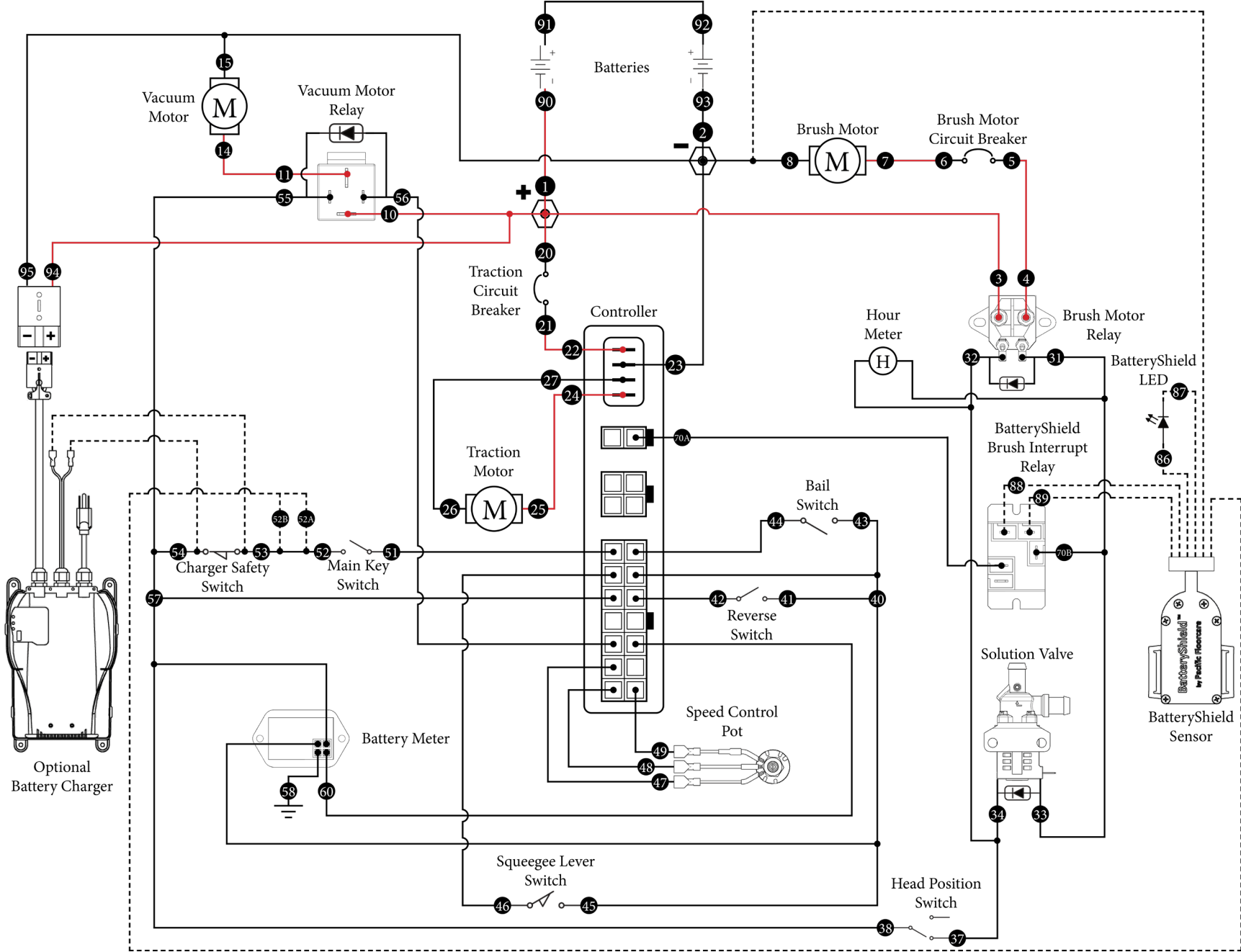

--- Wires represented with dashed lines indicate optional equipment installation

RETURN TO
TABLE OF
CONTENTS

S-20 ORBITAL

AFTER SERIAL NUMBER 113191

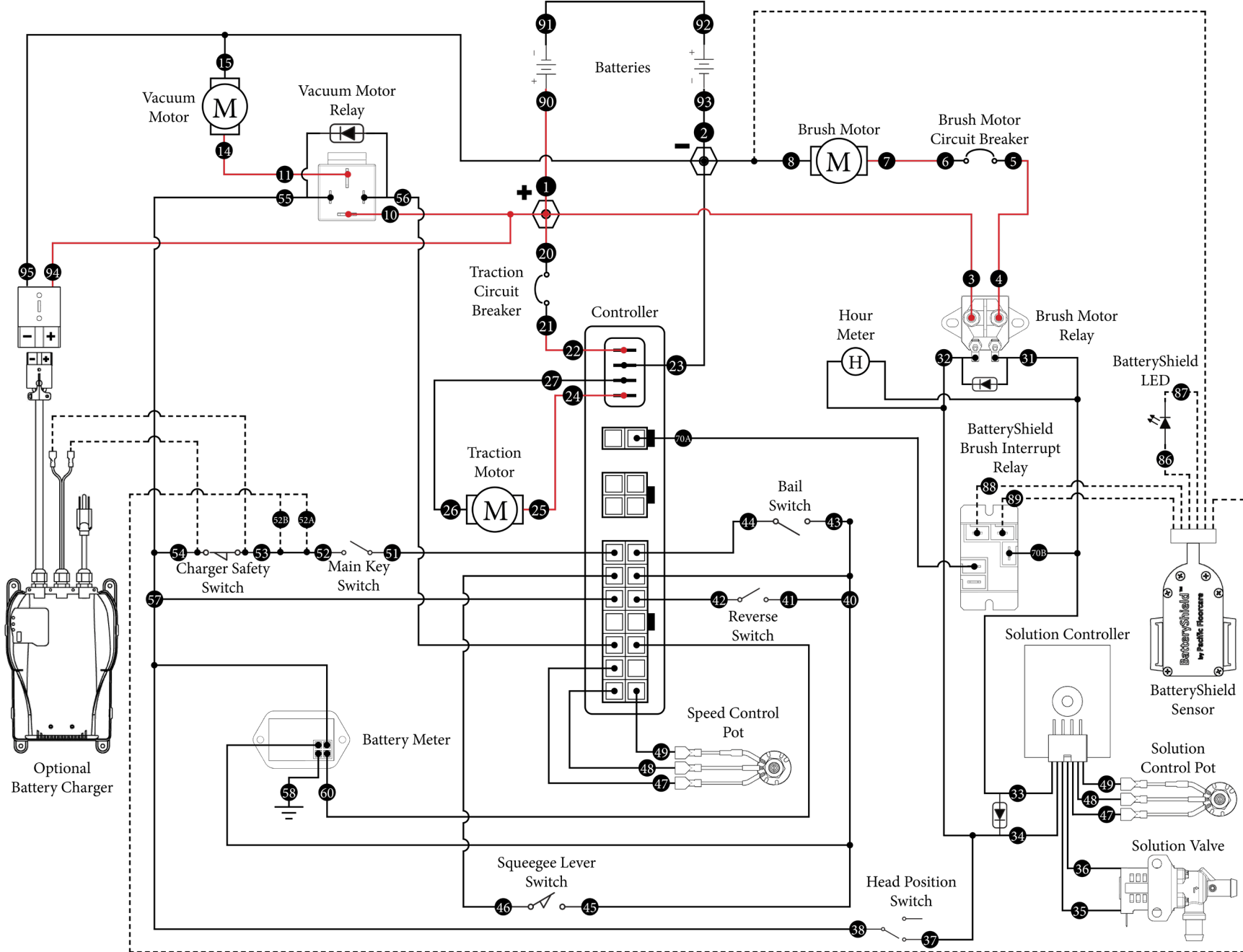

--- Wires represented with dashed lines indicate optional equipment installation

RETURN TO
TABLE OF
CONTENTS

S-20 PAD/BRUSH ASSIST ALL SERIAL NUMBERS

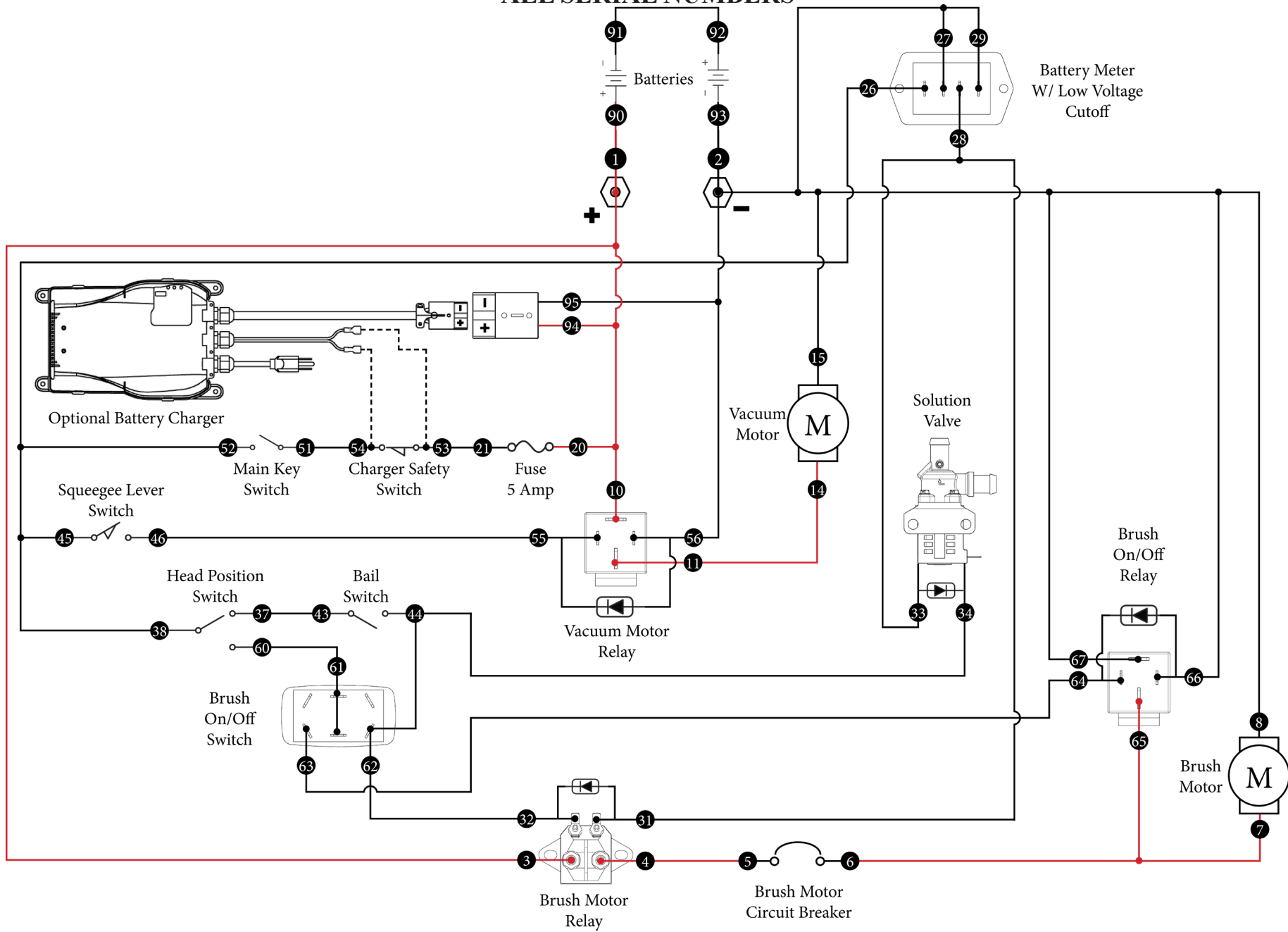

--- Wires represented with dashed lines indicate optional equipment installation

RETURN TO
TABLE OF
CONTENTS

OPTIONAL SCRUBSMART TELEMETRY SYSTEM

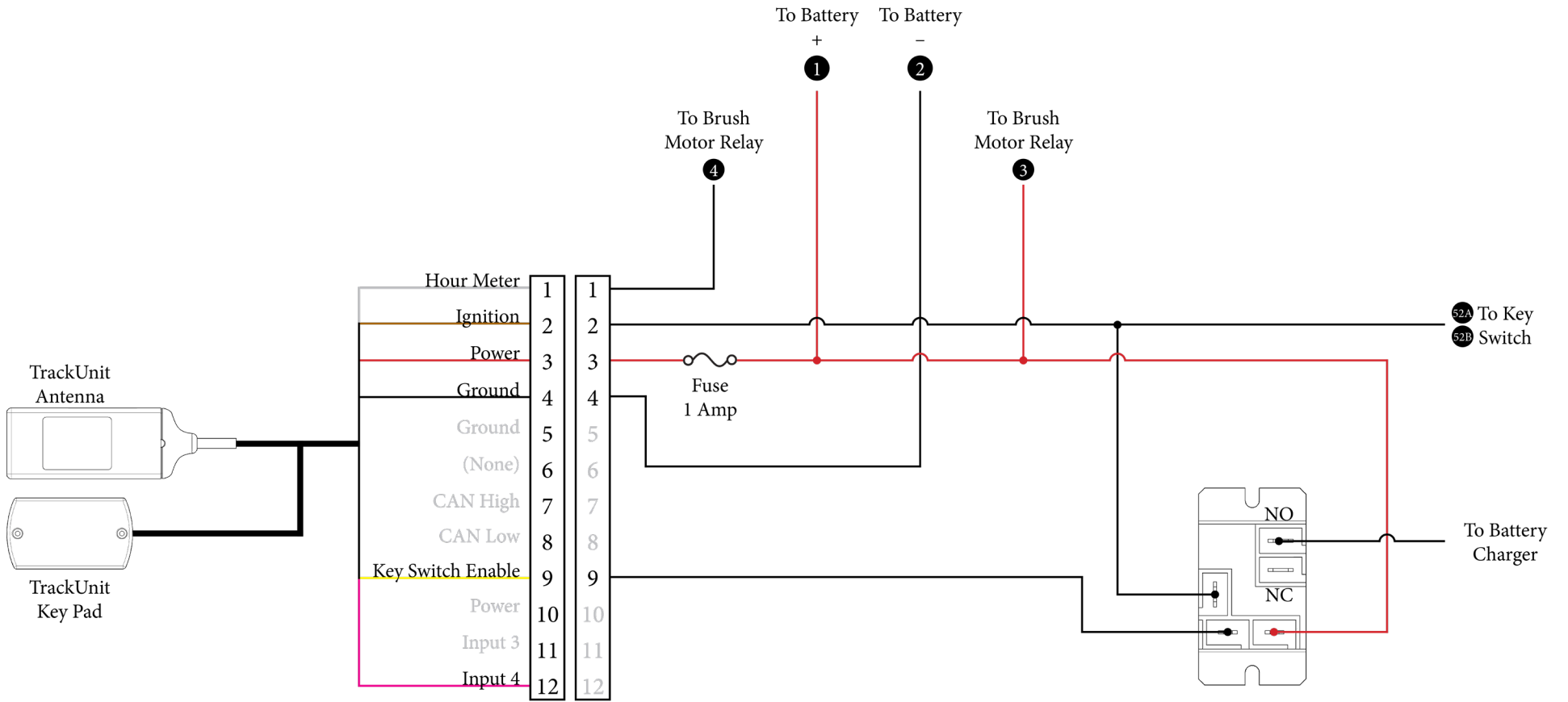

DATE	MAINTENANCE LOG

REVISION	REVISION LOG
2019.10.24	UPDATED BALLOONS FOR THE RECOVERY TANK, PAGE 37.
2019.11.27	ADDED BALLOON FOR THE VACUUM MOTOR, PAGE 37.
2020.2.5	ADDED ALL APPLICABLE INFORMATION FOR THE S-20HD & MISC. CORRECTIONS.
2020.2.13	ADDED MISSING SQUEEGEE ASSEMBLY PART NUMBERS, PAGE 42.
2020.2.20	UPDATE PART NUMBERS, PAGES 48 & 50. UPDATE WARRANTY INFORMATION
2020.7.29	UPDATE WARRANTY INFORMATION
2020.10.16	UPDATED WATERING LEAD ACID BATTERY W/ HYDROLINK, PAGE 8.
2021.1.5	UPDATED BATTERYSHIELD WARRANTY POLICY
2021.2.8	UPDATED IMAGES AND LAYOUT
2021.3.18	UPDATE TRACTION FRAME ASSEMBLY PARTS DIAGRAMS, PAGE 27.
2021.3.30	UPDATED PART DESCRIPTION FOR 855204, PAGES 47 & 49
2021.4.15	REMOVED WARRANTY STATEMENT.
2021.12.2	MULTIPLE UPDATES. UPDATED PG 34. ADDED PAGES 41 & 52.
2022.1.24	ADDED NOTES, PAGE 44.
2022.3.17	ADDED TELEMETRY SYSTEM INFORMATION.
2022.7.29	UPDATE HEAD LIFT DIAGRAMS, PAGES 29-31. UPDATED ORBITAL HEAD, PAGE 56.
2022.8.22	UPDATED DISC SCRUB HEADS, PAGES 49-54.
2023.3.9	UPDATED PAGES 32, 35-39, & 41-42
2023.11.22	UPDATE ALL WIRING DIAGRAMS. UPDATED PAGE 56.
2023.12.18	CORRECTED TYPO PAGE 65. UPDATED PAGE 39.
2024.1.15	UPDATED PAGES 35-39 & 63-64.

PAGE INTENTIONALLY BLANK



PACIFIC[®]
F L O O R C A R E

PURPOSE BUILT.[®]

www.pacificfloorcare.com